

Thru-Air® Airbrick Extraction Outlets

Code: **G940/G941/G942/G943**

Description

The Thru-Air product is designed to provide a ventilation outlet/inlet using a 4/5/6inch Telescopic pipe to a Manthorpe single/double/triple airbrick. Each thru...air unit allows for an extraction system to be conveniently built into the brickwork, eliminating the need for retrospective core drilling. The telescopic element allows the installer to extend or reduce the length of the pipe to suit the thickness of the wall and ducting connection.

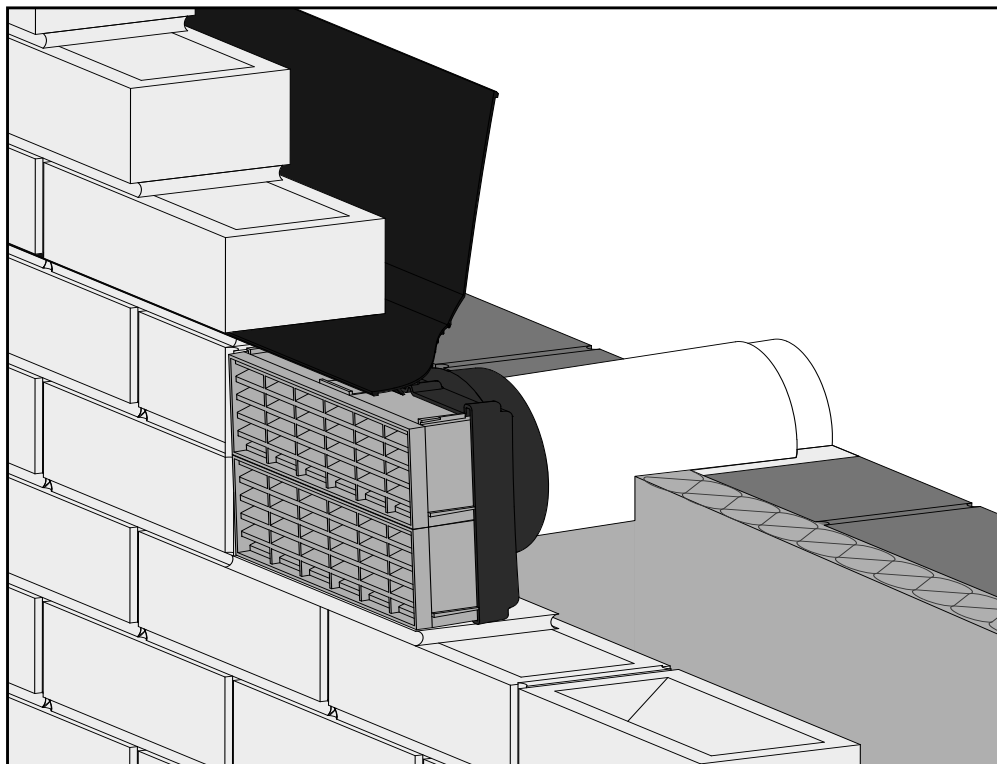

Product Code	G940	G941	G942	G943
Geometric Free Area	6,400mm ²	7,300mm ²	11,000mm ²	16,100mm ²
Box Weight /kg	0.5	0.6	0.7	0.9
Colour	Standard Colours: Terracotta / Buff / Blue Black Made to Order: Brown / White / Grey			
Packing Details	1 per box			
Material	Airbrick : Polypropylene Pipe Adapter : ABS Telescopic Pipe : PVCu			

MANTHORPE BUILDING PRODUCTS LTD
MANTHORPE HOUSE
BRITAIN DRIVE
CODNOR GATE BUSINESS PARK
RIPLEY
DERBYSHIRE DE5 3ND

TEL: 01773 303 000
FAX: 01773 303 300
EMAIL:
mbp.care@manthorpebp.co.uk
WEB:
www.manthorpebp.co.uk

DRAWN	ISSUE DRAWN
K.B. 18/12/19	B.H. 20/01/23

The company maintains a policy of continuous development of its product range and reserves the right to amend the specification without notice.

DRG No

MBP 8356

Page 1 of 4

Issue

08

Thru-Air® Airbrick Extraction Outlets

Code: **G940/G941/G942/G943**

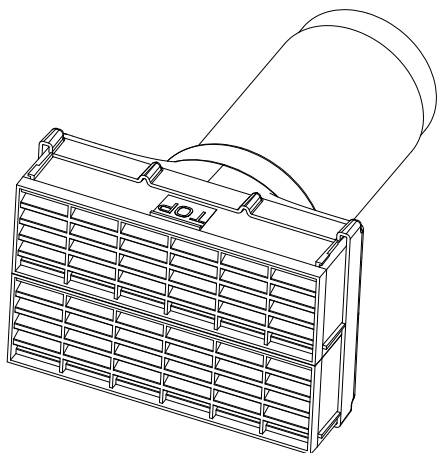

Dimensions (mm)	G940	G941	G942	G943
A	80	150	150	218
B\varnothing	100	100	121.5	146.5
C\varnothing	103.5	103.5	125	150

(Dimensions in mm)

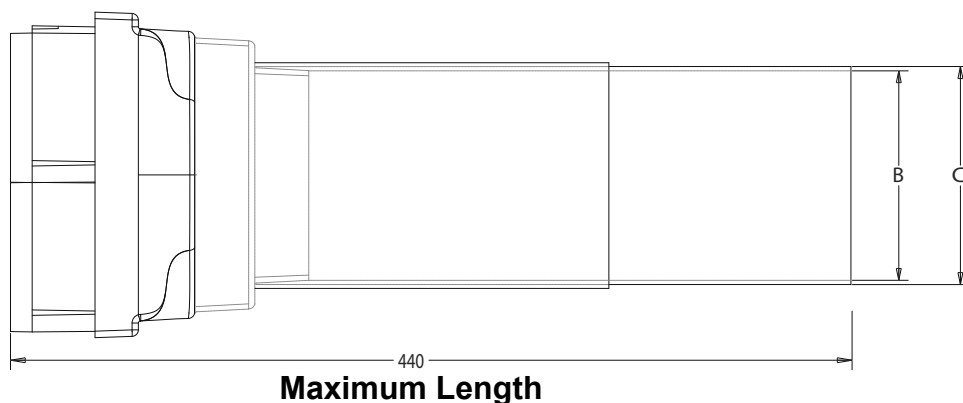
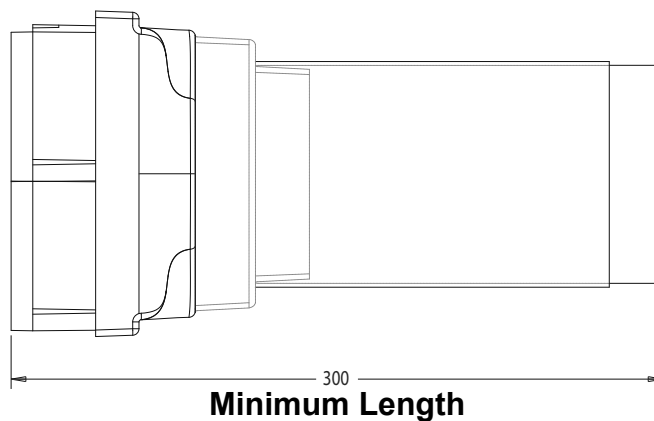
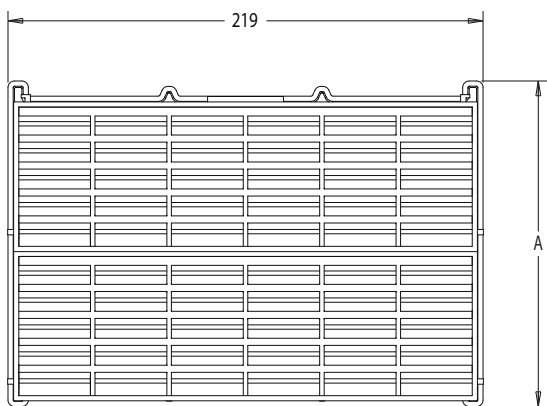

MANTHORPE BUILDING PRODUCTS LTD
 MANTHORPE HOUSE
 BRITAIN DRIVE
 CODNOR GATE BUSINESS PARK
 RIPLEY
 DERBYSHIRE DE5 3ND

TEL: 01773 303 000
 FAX: 01773 303 300
 EMAIL:
 mbp.care@manthorpebp.co.uk
 WEB:
 www.manthorpebp.co.uk

DRAWN	ISSUE DRAWN
K.B. 18/12/19	B.H. 20/01/23

The company maintains a policy of continuous development of its product range and reserves the right to amend the specification without notice.

DRG No

MBP 8356

Page 2 of 4

Issue

08

Thru-Air® Airbrick Extraction Outlets

Code: **G940/G941/G942/G943**

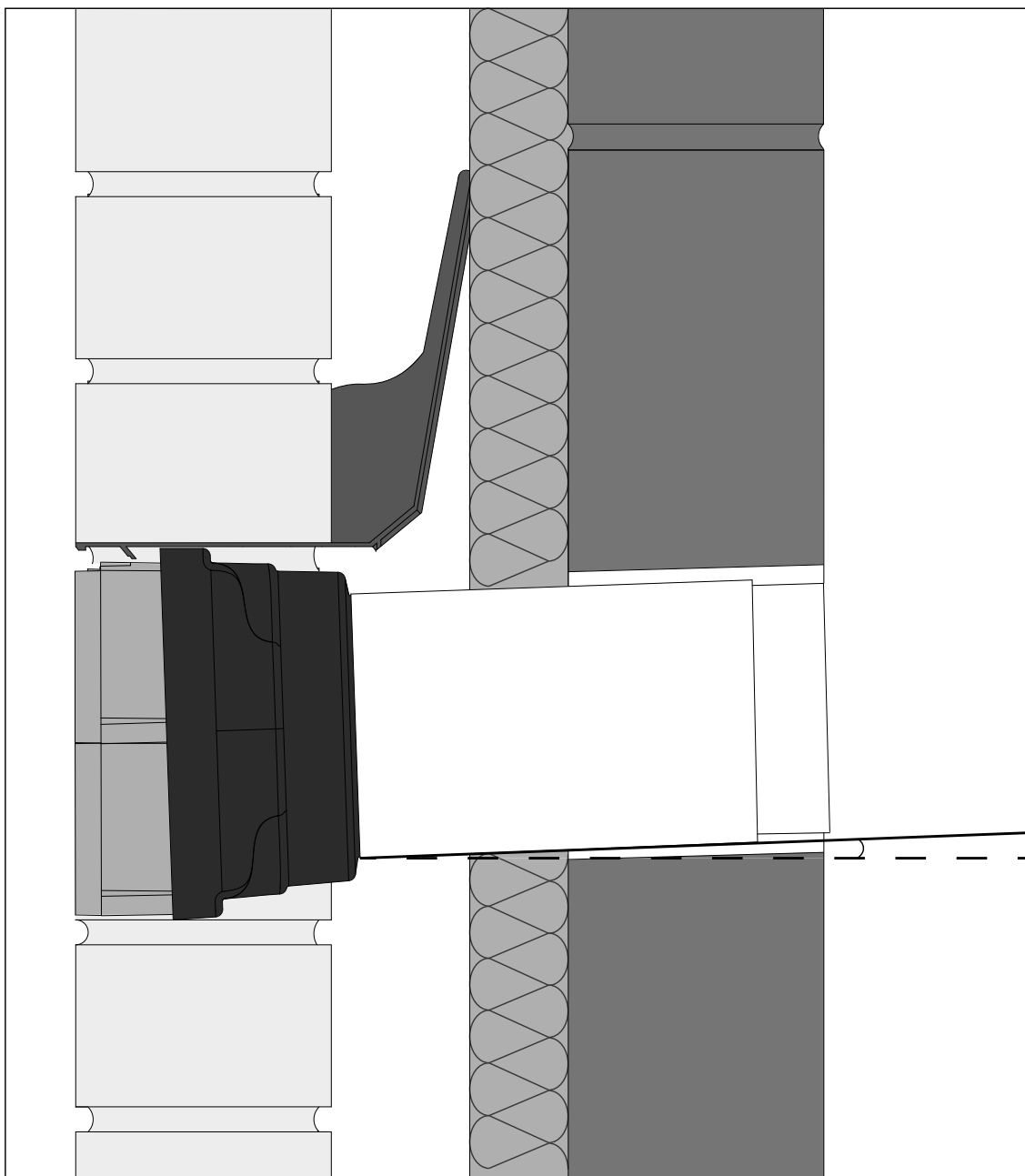

Fitting Instructions

Build the Thru-Air product into the brickwork as the masonry proceeds. The placement of the product is determined by the position of the internal extraction system. The product must be installed angled slightly down towards the external brickwork to allow for any condensation build up to drain out via the Airbricks. If required the detail can be finished off with a suitable cavity tray (including weep vents) above the product to prevent water ingress.

MANTHORPE BUILDING PRODUCTS LTD
 MANTHORPE HOUSE
 BRITTAIN DRIVE
 CODNOR GATE BUSINESS PARK
 RIPLEY
 DERBYSHIRE DE5 3ND

TEL: 01773 303 000
 FAX: 01773 303 300
 EMAIL:
 mbp.care@manthorpebp.co.uk
 WEB:
 www.manthorpebp.co.uk

DRAWN	ISSUE DRAWN
K.B. 18/12/19	B.H. 20/01/23

The company maintains a policy of continuous development of its product range and reserves the right to amend the specification without notice.

DRG No

MBP 8356

Page 3 of 4

Issue

08

Thru-Air[®] Airbrick Extraction Outlets

Code: **G940/G941/G942/G943**

Aerodynamic Characteristics Of Thru-Air[®] Range

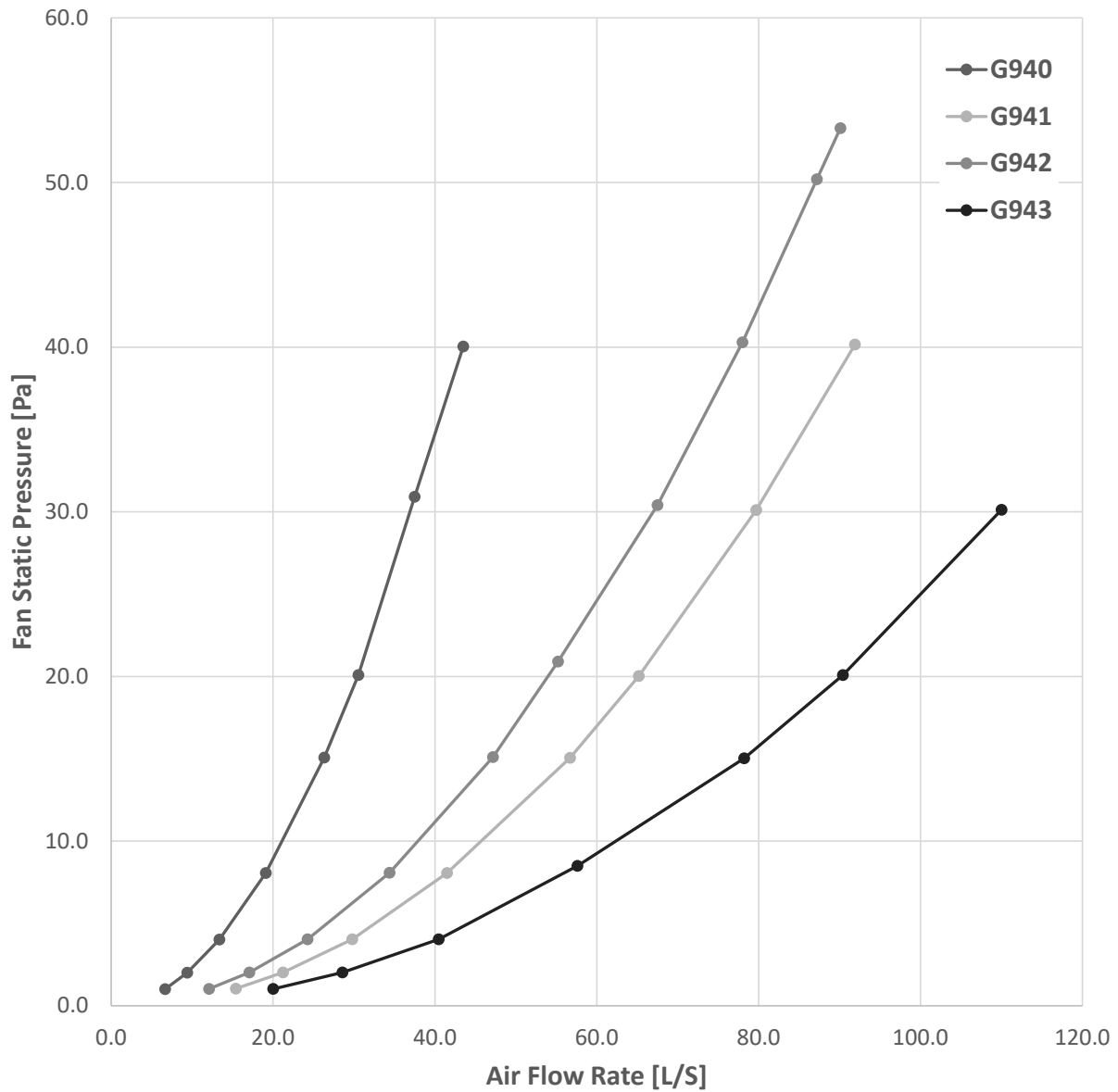

G940	Dp [Pa]	1.01	2.01	4.02	8.07	15.07	20.08	30.91	40.04	-	-
	Vol [l/s]	6.66	9.40	13.37	19.10	26.32	30.54	37.49	43.50	-	-
G941	Dp [Pa]	1.04	2.02	4.04	8.07	15.06	20.02	30.10	40.16	-	-
	Vol [l/s]	15.40	21.24	29.78	41.51	56.70	65.20	79.70	91.90	-	-
G942	Dp [Pa]	1.03	2.02	4.03	8.08	15.10	20.90	30.40	40.30	50.20	53.30
	Vol [l/s]	12.10	17.07	24.25	34.41	47.17	55.20	67.50	78.00	87.20	90.10
G943	Dp [Pa]	1.02	2.02	4.04	8.50	15.03	20.08	30.12	-	-	-
	Vol [l/s]	20.02	28.57	40.46	57.60	78.20	90.40	110.00	-	-	-

MANTHORPE BUILDING PRODUCTS LTD
 MANTHORPE HOUSE
 BRITAIN DRIVE
 CODNOR GATE BUSINESS PARK
 RIPLEY
 DERBYSHIRE DE5 3ND

TEL: 01773 303 000
 FAX: 01773 303 300
 EMAIL:
 mbp.care@manthorpebp.co.uk
 WEB:
 www.manthorpebp.co.uk

DRAWN	ISSUE DRAWN
K.B. 18/12/19	B.H. 20/01/23

The company maintains a policy of continuous development of its product range and reserves the right to amend the specification without notice.

DRG No

MBP 8356

Page 4 of 4

Issue

08