

SmartVerge® Interlocking Plain Tile Dry Verge - System Overview

Code: **GPPV-IPT**

Description

The SmartVerge® Interlocking Plain Tile dry verge system provides a neat and attractive finish to the verge detail of a roof covered with interlocking plain tiles. The design of the system is ambidextrous and allows the units to be installed to either hand of the verge; with the cambered flanges designed to lay perfectly flat to the tile surface thanks to the unique split fixing plate, helping to eliminate tile kick up and increase the effective water runoff from the verge.

The system is mortar-free and can be fixed in all weather conditions, easily capping over each tile in succession and once fitted they are weatherproof and maintenance free. The handed verge units are available in a range of colours to compliment any variation of roof design.

Angled or round Ridge End Caps are available to protect the end of the ridge while the unique Eaves Closure with its simpler fitting and colour matched external fixing at the base of the verge, secures the first unit and prevents ingress into the roof space from birds and large insects.

Features

- Fast & easy to install, mortar-free, dry fix verge system.
- Suits small format concrete interlocking plain tiles.
- Can be fitted with a batten gauge of 173mm to 190mm.
- Ambidextrous units suit both hands of the verge.
- Protects the verge from exposure to the elements.
- Also helps to prevent the entry of birds and large insects.
- Suitable for both new build and refurbishment details.
- Can be installed on roof pitches between 22.5° and 55°.
- Drains moisture away from the wall to prevent staining.
- Manufactured from UV stabilised polypropylene.
- Available in a range of colours to suit various roof types.
- Meets BS 5534 requirements for mechanical fixing.
- System independently wind tunnel tested at the BRE.

References

BSI: BS 5534:2014 Code of Practice for Slating and Tiling
 BRE: Wind Tunnel Test report number P123548-1000
 BSI: BS 8612:2018
 NHBC: Standards - Chapter 7.2 Pitched Roofs

Ambidextrous Interlocking Plain Tile Dry Verge Unit (GPPV-IPT)

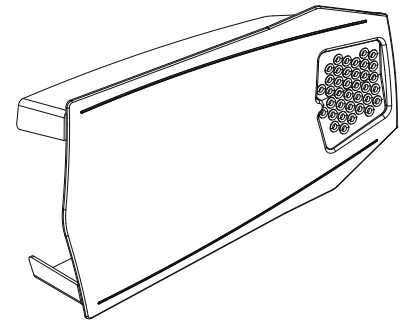

Angled Ridge End Cap (GPPV-END-A)

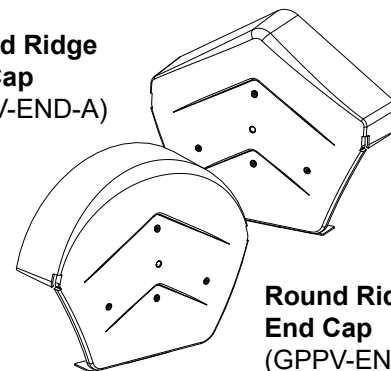

Round Ridge End Cap (GPPV-END-R)

Eaves Closure Unit (GPPV-IPEC)

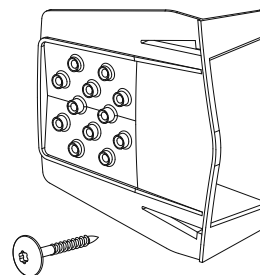

Batten End Clip (GDV-BEC)

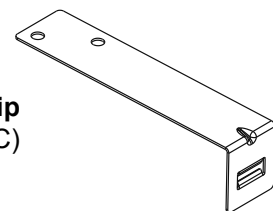

BS 8612 Specifications

- Independently tested to conform with the requirements of BS 8612.
- Performance data for the tests conducted on this product is available upon request.

MANTHORPE BUILDING PRODUCTS LTD
 MANTHORPE HOUSE
 BRITAIN DRIVE
 CODNOR GATE BUSINESS PARK
 RIPLEY
 DERBYSHIRE DE5 3ND

TEL: 01773 303 000
 FAX: 01773 303 300
 EMAIL: mbp.care@manthorpebp.co.uk
 WEB: www.manthorpebp.co.uk

DRAWN	ISSUE DRAWN
B.H. 05/09/22	B.H. 05/09/22

The company maintains a policy of continuous development of its product range and reserves the right to amend the specification without notice.

DRG No	Issue
MBP 8373	01