

SmartVerge® Interlocking Plain Tile Dry Verge - Eaves Closure

Code: **GPPV-IPEC**

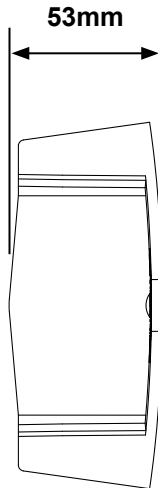
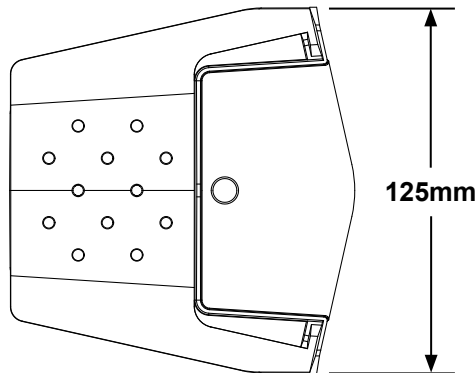
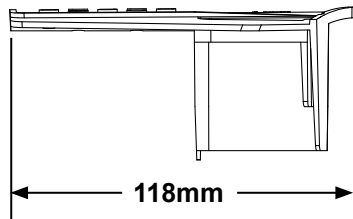

### Ambidextrous Split Nail Face Rebated Eaves Closure

*inc. screw fixing*

For use with the:

**GPPV-IPT & GPPV-TLE**

SmartVerge Dry Verge systems

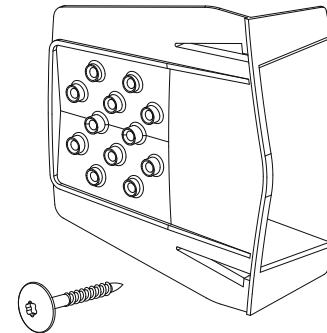

#### Description

This unique eaves closure unit and fixing is designed to secure the lower end of the first verge unit of the run at the eaves, providing a robust anchor for the remainder of the system.

While other systems require the closure to be fitted independently of the verge unit, causing issues with positioning and alignment, the unique design of the rebated, split nail face unit allows it to be installed at the same time as the verge unit, ensuring they are fully engaged and properly aligned. The colour matched external fixing can then be used to secure both into the continuous verge batten.

The design is ambidextrous in nature and can be used on both verges of the roof, with the rebated nature of the unit allowing adequate clearance for any extended guttering detail.

#### References

BSI: BS 5534:2014 Code of Practice for Slating and Tiling  
BRE: Wind Tunnel Test report number P123548-1000  
BSI: BS 8612:2018  
NHBC: Standards - Chapter 7.2 Pitched Roofs

#### BS 8612 Specifications

Independently tested to conform with the requirements of the BS 8612 standard. Performance data for the tests conducted on this product is available upon request.

#### Features

- Fast and easy to install, dry fix eaves closure system.
- Provides a mechanically fixed, mortar-free solution.
- Anchors for the base of the first verge unit at the eaves.
- Helps to prevent the entry of birds and large insects.
- Rebated end provides clearance for the gutter overhang.
- Manufactured from UV stabilised polypropylene.
- Supplied with a colour matched external fixing screw.
- Available in a range of colours to suit various roof types.
- Meets BS 5534 requirements for mechanical fixing.
- System independently wind tunnel tested at the BRE.

<b>Packing Details</b>	<b>10 per box.</b> Packed in bags of 2 units, including the screw fixings. 5 bags per box.
<b>Box Weight</b>	0.8 kg (approx.)
<b>Part Weight</b>	0.041 kg
<b>Materials</b>	<b>Closure</b> - Polypropylene <b>Screw</b> - Powder coated stainless steel
<b>Colours</b>	(TR) Terracotta, (BR) Brown, (GR) Slate Grey, (BL) Black & (AR) Antique Red

MANTHORPE BUILDING PRODUCTS LTD  
MANTHORPE HOUSE  
BRITAIN DRIVE  
CODNOR GATE BUSINESS PARK  
RIPLEY  
DERBYSHIRE DE5 3ND

TEL: 01773 303 000  
FAX: 01773 303 300  
EMAIL:  
mbp.care@manthorpebp.co.uk  
WEB:  
www.manthorpebp.co.uk

<b>DRAWN</b>	<b>ISSUE DRAWN</b>
B.H. 05/09/22	B.H. 29/02/24
The company maintains a policy of continuous development of its product range and reserves the right to amend the specification without notice.	

<b>DRG No</b>	<b>Issue</b>
<b>MBP 8375</b>	<b>02</b>