

25mm Over Fascia Ventilator

Code: **G2500N**

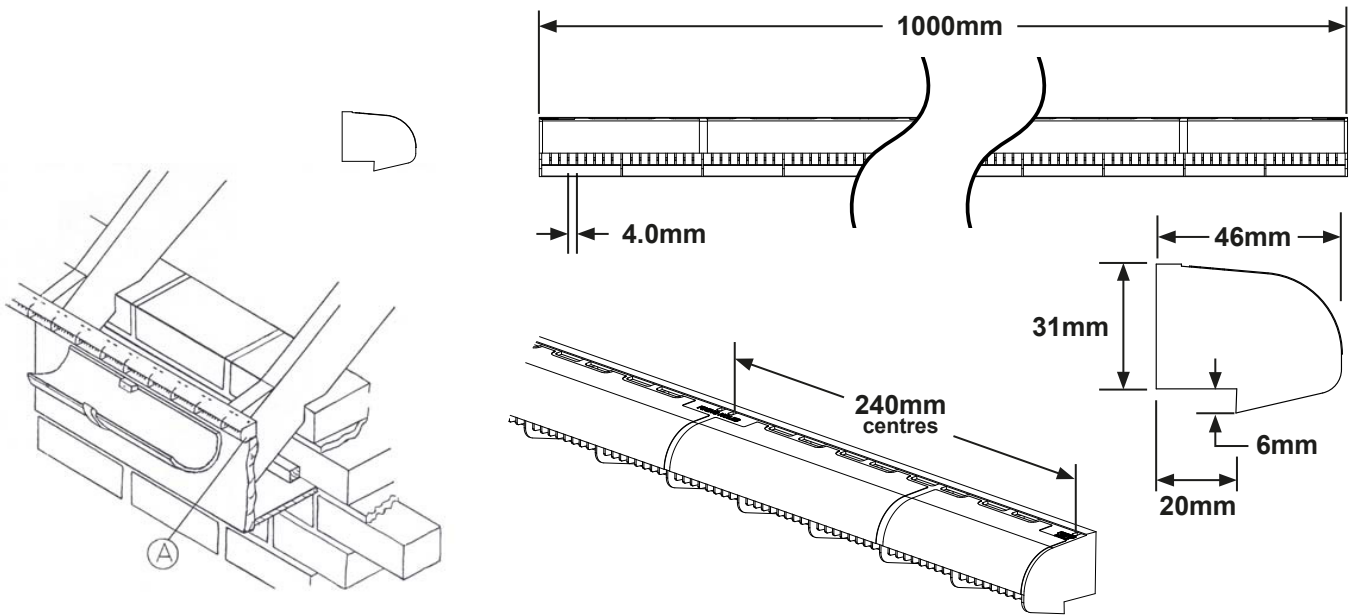

Description

The **G2500N** 25mm Over Fascia Ventilator is designed to discreetly ensure a positive airflow into the roof space between the felt and the top of the fascia board, making it ideal for both new build and re-roofing situations.

The vent consists of evenly spaced openings specifically sized to prohibit large insects gaining access but wide enough not to be blocked by debris, paint or water droplets.

The product is designed with clear fixing points and a smooth leading edge allowing it to sit discreetly on top of the fascia board beneath the felt. The vent is robust enough to be used with any roof tile regardless of the profile and can be fitted with plain tiles or slates.

Fitting Instructions

The G2500N Over Fascia Ventilator (A) should be nailed to the top of the fascia board through the fixing holes provided along the full length of the eaves as shown.

Use in conjunction with other products from the Manthorpe range to provide a complete roof ventilation system.

Features

- Provides 25,000mm² airflow per metre
- Units come in 1 metre lengths
- Fits with both roof tiles and slates
- Discreet, low profile design
- Fixes easily into the top of the fascia board
- Fitted with integral flyscreen
- Versatile design can be used in other roofing details

Colour	Black
Packing Details	20 x 1m lengths per box.
Box Weight	3.9kg (approx.)
Part Weight	0.18 kg
Material	Polypropylene
Free Area	25,000mm ² /M Equivalent to a continuous 10mm

References

BSI: BS 5534 Code of Practice for Slating and Tiling
 BSI: BS 5250 Code of Practice for the Control of Condensation
 BRE: DIGEST 262/270
 NHBC: Standards - Chapter 7.2 Pitched Roofs

MANTHORPE BUILDING PRODUCTS LTD
 MANTHORPE HOUSE
 BRITAIN DRIVE
 CODNOR GATE BUSINESS PARK
 RIPLEY
 DERBYSHIRE DE5 3ND

TEL: 01773 303 000
 FAX: 01773 303 300
 EMAIL:
 mbp.care@manthorpebp.co.uk
 WEB:
 www.manthorpebp.co.uk

DRAWN	ISSUE DRAWN
B.H. 01/08/03	B.H. 27/01/23

The company maintains a policy of continuous development of its product range and reserves the right to amend the specification without notice.

DRG No	Issue
MBP 8011	03