

Thermal Cavity Closer - Double Flange

Code: **G240**

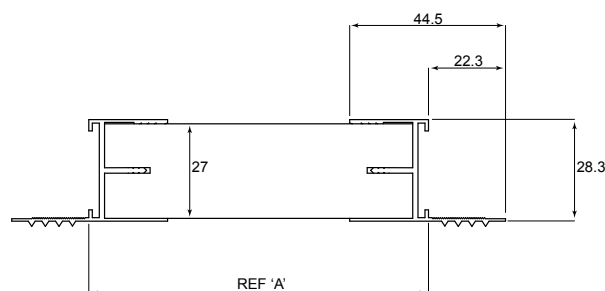
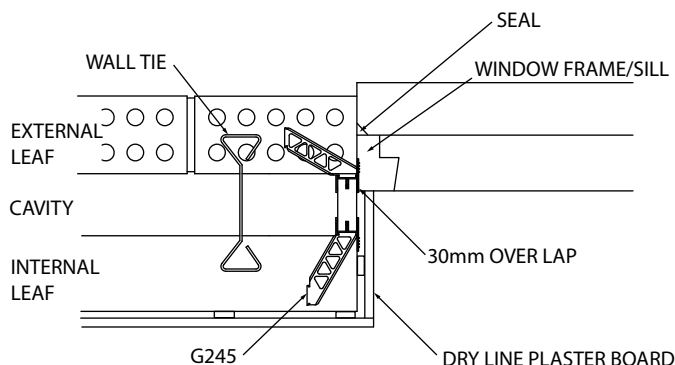
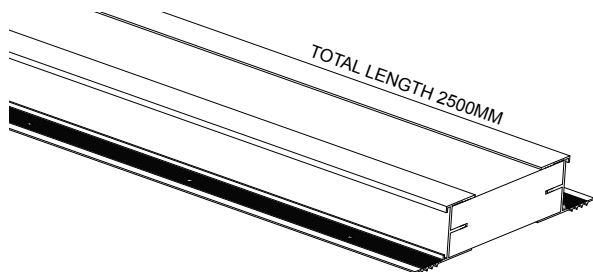

Description

The Manthorpe double flange G240 Thermal Cavity Closer suits standard vertical cavity details and sill details. It provides an economical solution to cold bridging problems and is available in a range of sizes to suit varying cavity widths. It can be easily be installed with no special fixing requirements or tools.

The Manthorpe G240 Cavity Closer not only provides a thermal break to the cavity but also acts as an effective vertical DPC barrier.

It achieves the required Thermal Resistance (R value) at the reveal of door and window openings when the frames are fixed to allow a 30mm overlap into the cavity.

PRODUCT CODE	DIMENSION REFERENCE 'A'	WEIGHT PER PACK
G240/100	100 +0/-2	7.20 kg
G240/125	125 +0/-2	7.60 kg
G240/150	150 +0/-2	8.00 kg
G240/175	175 +0/-2	8.40 kg
G240/200	200 +0/-2	8.80 kg

Stock cavity widths are listed above, additional intermediate sizes from 50-100mm and 200-300mm can be made to order.

	EXTRUSION	STYROFOAM
COLOUR	WHITE	BLACK
PACKING DETAILS	6 LENGTHS PER PACK	
MATERIAL	UPVC	CFC free extruded polystyrene
MANUFACTURING PROCESS	EXTRUSION	
K VALUE	-	0.035 W/mK
ODP	-	0
GWP	-	LESS THAN 5
CFC	-	FREE

References	
BRE:	DIGEST 262
BRE:	IP 1/06
BSI:	BS5250
DOE:	Building Regs L
NHBC:	Good Practice Guide
NHBC:	Standards
BBA Certificate Number: 96/3226	

MANTHORPE BUILDING PRODUCTS LTD
 MANTHORPE HOUSE
 BRITAIN DRIVE
 CODNOR GATE BUSINESS PARK
 RIPLEY
 DERBYSHIRE DE5 3ND

TEL: 01773 303 000
 FAX: 01773 303 300
 EMAIL: mbp.care@manthorpebp.co.uk
 WEB: www.manthorpebp.co.uk

DRAWN	ISSUE DRAWN
M.R. 21/10/08	B.H. 12/02/24

The company maintains a policy of continuous development of its product range and reserves the right to amend the specification without notice.

DRG No

MBP 8085

Issue

08
1 of 2

Thermal Cavity Closer - Double Flange

Code: **G240**

Preparation

Cut two jamb sections 75mm over size. Trim back the lower flanges on the jambs by 75mm (figure 1) to allow them to drop into the cavity below sill level. Cut the sill section to length. Short lengths of cavity closer can be joined together using G245 fixing clips, ensuring the butt joint slopes down at 45° towards the outer leaf as shown (figure 4).

These sections can now be used in one of three ways:

1. Preformed into cavity frames (figure 2) to be inserted at sill level and tied into the reveal as it is built with G245 fixing clips.
2. Used in individual lengths to be inserted into the completed cavity reveal prior to the window frame being installed, screwed or nailed into the masonry.
3. Nailed to the frame (figure 3) prior to fitting.

To form a cavity closer frame, cut a top section 150mm over size, with the flanges trimmed back by 75mm on both ends. Using eight right angle fixing clips assemble the corners as shown (figure 2).

The top section can be removed and re-used on completion of the opening. For large windows diagonal bracing may be required to maintain the shape.

Installation

Brick up the cavity wall to sill height in the conventional manner and position the cavity closer.

DPC should be fitted under the window sill in line with current building practice (Figure 6).

Continue to brick up the wall construction using sufficient fixing clips to hold the closer in place, ensuring that the excess mortar is removed from the closer.

Closer profiles are available with a double flange for standard reveals (Figure 5) and a single flange for rebated cavity reveals (Figure 7).

The installation is completed by the application of a weatherproof seal between the frame and the outer leaf and by dry lining or plastering at the internal reveal.

The cavity closer is a non-load bearing product and must not be used as replacement for traditional methods of fixing window and door frames to the masonry.

FIG. 1

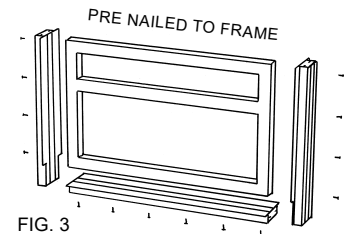
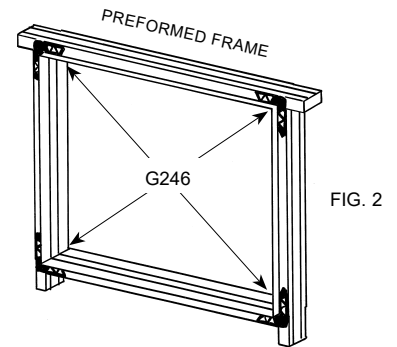
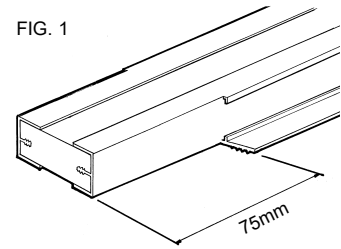

FIG. 4

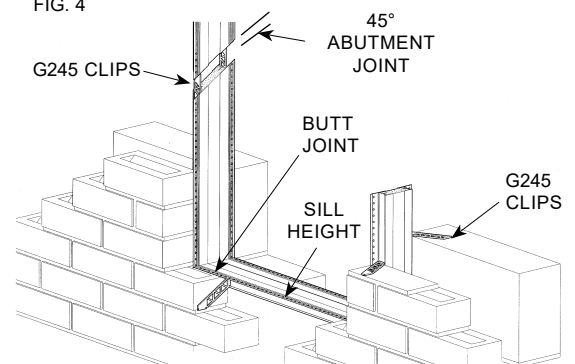

FIG. 5

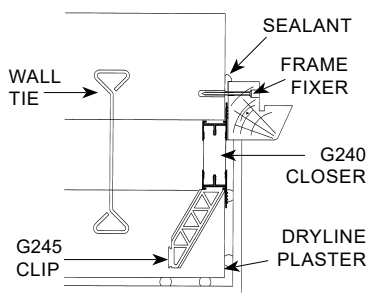

FIG. 6

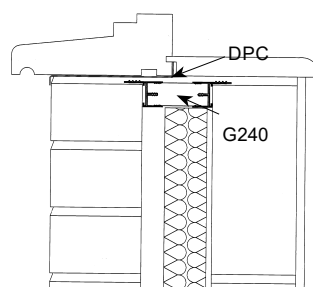
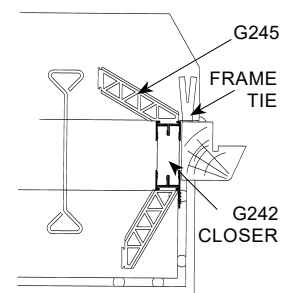

FIG. 7



MANTHORPE BUILDING PRODUCTS LTD
MANTHORPE HOUSE
BRITAIN DRIVE
CODNOR GATE BUSINESS PARK
RIPLEY
DERBYSHIRE DE5 3ND

TEL: 01773 303 000
FAX: 01773 303 300
EMAIL: mbp.care@manthorpebp.co.uk
WEB: www.manthorpebp.co.uk

DRAWN	ISSUE DRAWN
M.R. 21/10/08	B.H. 12/02/24

The company maintains a policy of continuous development of its product range and reserves the right to amend the specification without notice.

DRG No

MBP 8085

Issue

08
2 of 2