

Non-Combustible Extension Sleeve

Code: **G1361**

Description

The G1361 Non-Combustible Extension Sleeve is designed to provide incremental depth and span extensions to the range of Non-combustible Underfloor Ventilation products to provide a clear, unobstructed airflow passage to a void beneath an insulated suspended floor. The vent is constructed from Stainless Steel in order to be non-combustible and offer no contribution to fire.

The evolving requirements of Part L of the Building Regulations in pursuit of energy efficiency have led to an increase in the depth of thermal insulation in suspended floors along with an increase in cavity widths to accommodate greater amounts of cavity wall insulation. This has meant that clear access to an underfloor void may require a significant vertical drop along with a large horizontal span to bridge over from the inlet point in the outer leaf.

The range of Non-Combustible Underfloor Vents (G1365 & G1368) already cover a wide range of course depths and wall thickness, however for those detail which require it the G1361 can extend them even further. The Extension Sleeve will add an extra 150mm for each unit used, that is 2 further courses when used vertically and 150mm when used horizontally on either the upper or lower outlet.

For plinth brick and wider bed depth details the G1361 can be installed into the upper outlet of a Non-Combustible Underfloor Vent, with the Grille Slip affixed to the opposing end to allow the vent to extend across an increased bed depth of the outlet leaf beyond that of a single brick (102mm).

Due to the design, manufacture and telescopic adjustability of the products, the ducting paths are not airtight along their length there will be a limited degree of leakage both into and from the cavity void to the ducting channel.

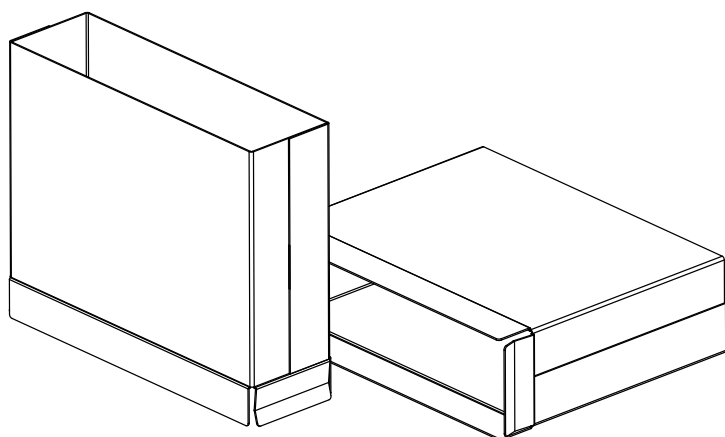

Packing Details	1 per box
Box Weight	0.82 kg
Part Weight	0.67 kg
Material	304 Stainless Steel
Manufacturing Process	Fabricated
Free Airflow	6,500 mm ²
Extension	150mm (2 courses vertically)

MANTHORPE BUILDING PRODUCTS LTD
MANTHORPE HOUSE
BRITAIN DRIVE
CODNOR GATE BUSINESS PARK
RIPLEY
DERBYSHIRE DE5 3ND

TEL: 01773 303 000
FAX: 01773 303 300
EMAIL: mbp.care@manthorpebp.co.uk
WEB: www.manthorpebp.co.uk

DRAWN	ISSUE DRAWN
B.H. 03/03/21	B.H. 15/02/23

The company maintains a policy of continuous development of its product range and reserves the right to amend the specification without notice.

DRG No

MBP 8370

Page 1 of 3

Issue

03

Non-Combustible Extension Sleeve

Code: **G1361**

Fitting Options

The Extension Sleeve can be fitted in three positions onto an Underfloor Vent; at the telescopic joint between the two halves to increase the vertical drop, horizontally off the lower outlet to increase the overall span through the wall or off the upper outlet to offset the Grille Slip in wider bed depth situations such as a plinth brick detail.

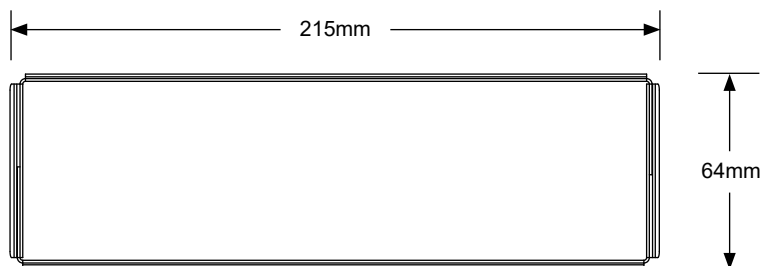
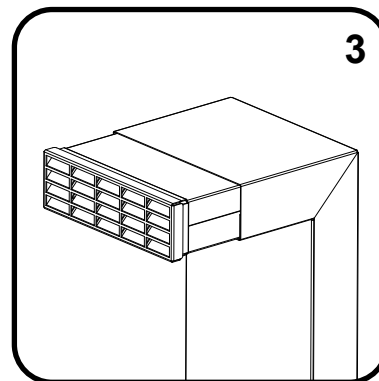
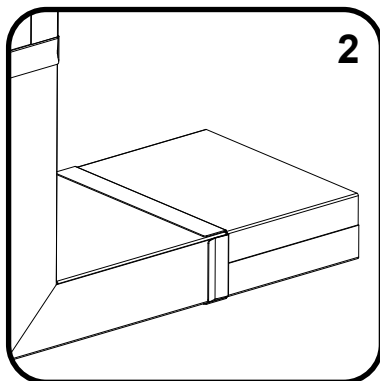
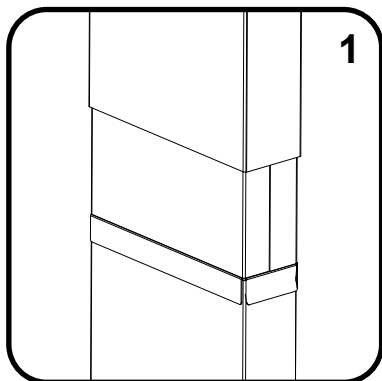

Note:

The two tabs along the shorter edge of the sleeve can be flexed inward or outward to adjust the interference with either the underfloor vent or grille slip depending on the specific fitting requirement of the sleeve.

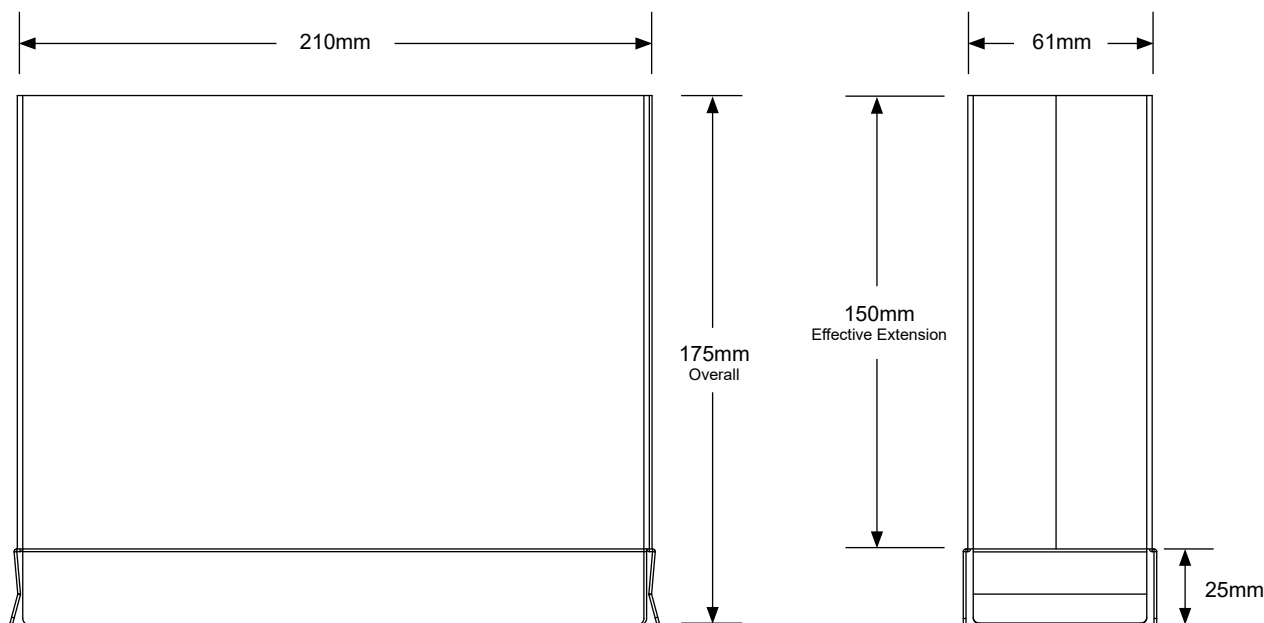

MANTHORPE BUILDING PRODUCTS LTD
 MANTHORPE HOUSE
 BRITAIN DRIVE
 CODNOR GATE BUSINESS PARK
 RIPLEY
 DERBYSHIRE DE5 3ND

TEL: 01773 303 000
 FAX: 01773 303 300
 EMAIL: mbp.care@manthorpebp.co.uk
 WEB: www.manthorpebp.co.uk

DRAWN	ISSUE DRAWN
B.H. 03/03/21	B.H. 15/02/23

The company maintains a policy of continuous development of its product range and reserves the right to amend the specification without notice.

DRG No

MBP 8370

Page 2 of 3

Issue

03

Non-Combustible Extension Sleeve

Code: **G1361**

Material Properties

As detailed in Building Regulations Approved Document B [2022]: Regulation 7(2) and Requirement B4 for use in relevant buildings, and to help meet Scottish Building Standards [Technical Handbook 2022: Domestic] Section 2.7:

The product is manufactured from a 304 grade of Stainless Steel, the ventilator ducting sections are considered A1 rated without the need for testing in accordance with the guidance of the European Commission Paper 96/603/EC as referenced in BS EN 13501-1:2018.

The grille slips are also manufactured from 304 Stainless Steel and are finished with an inorganic powder coating which has been tested to the requirements of EN 13823 and ISO 1716 and is classified as A2 s1 d0 according to BS EN 13501-1.

Stainless Steel grade 304 has good resistance to oxidation in intermittent service up to 870°C and in continuous service to 925°C.

Part B Considerations & Limitations

Due to the design, manufacture and telescopic adjustability of the products, the ducting paths are not airtight along their length there will be a limited degree of leakage both into and from the cavity void to the ducting channel. This means that while the ventilators are classed as A2-s3, d2 or better in accordance with Section 10.6 in that they will not contribute to fire in terms of a fuel source, the ducts are not classed as fire resistant.

The ventilators provide a ducting path through the cavity void and into the sub-floor void of the building. As the duct is not fire stopped and the telescopic joint between the upper and lower sections is not sealed, the movement of air is possible between these voids, which in the event of a fire could allow for the transition of hot gases from the duct into the adjacent voids.

The designed placement of the underfloor ventilator should only transition through the cavity wall outboard of the fire compartmentation of the dwelling, at no point should the duct path be penetrated fully through the compartment wall, floor or barrier construction.

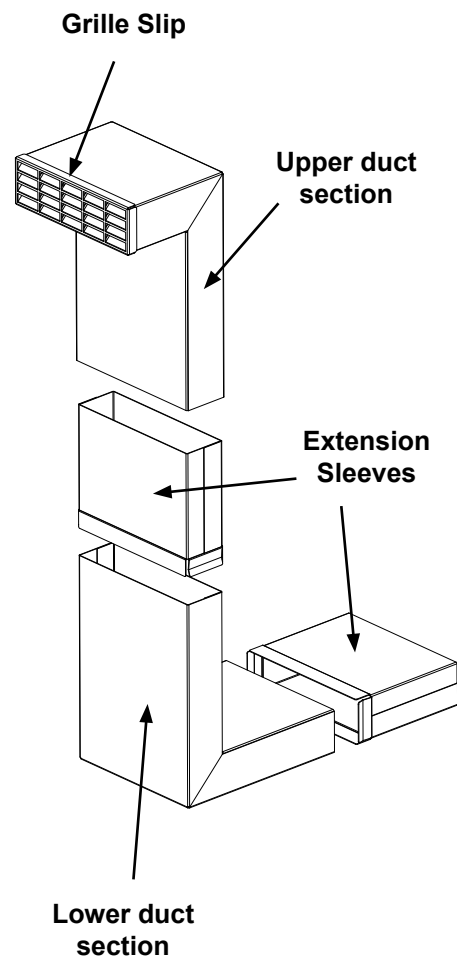

MANTHORPE BUILDING PRODUCTS LTD
 MANTHORPE HOUSE
 BRITAIN DRIVE
 CODNOR GATE BUSINESS PARK
 RIPLEY
 DERBYSHIRE DE5 3ND

TEL: 01773 303 000
 FAX: 01773 303 300
 EMAIL: mbp.care@manthorpebp.co.uk
 WEB: www.manthorpebp.co.uk

DRAWN	ISSUE DRAWN
B.H. 03/03/21	B.H. 15/02/23

The company maintains a policy of continuous development of its product range and reserves the right to amend the specification without notice.

DRG No

MBP 8370

Page 3 of 3

Issue

03