

Rafter Foot

CODE G750

Description

The Manthorpe Rafter Foot has been designed to create a mock open eaves detail, when a closed eaves construction with a sloping soffit board is required. Its versatile design allows for the installer to fix the product either from above the soffit board or from below, depending on the installers preference. Each Rafter Foot is fixed against the soffit board via a secure mechanical fixing (Please see fitting instructions for further details).

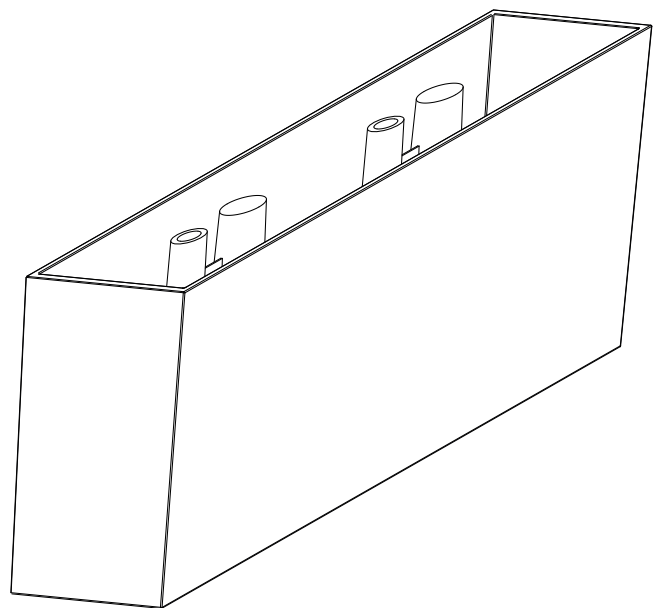
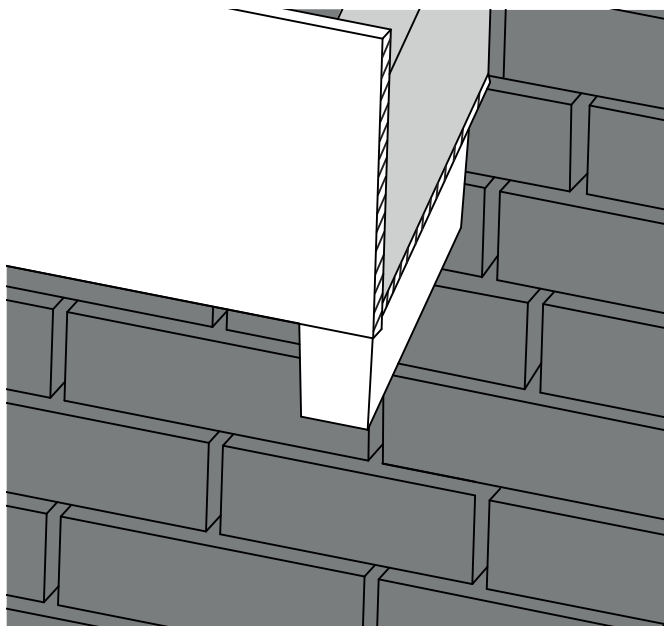

Parts Included

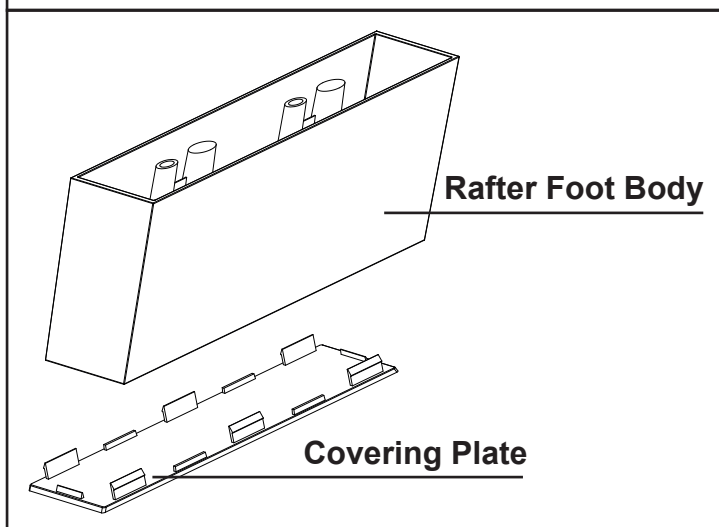

Colours	White
Packing Details	20 per box
Weight (Box of 20)	3kg per box
Material	PVC
Manufacturing Process	Injection Moulded

MANTHORPE BUILDING PRODUCTS LTD
 MANTHORPE HOUSE
 BRITAIN DRIVE
 CODNOR GATE BUSINESS PARK
 RIPLEY
 DERBYSHIRE DE5 3ND

TEL: 01773 303 000
 FAX: 01773 303 300
 EMAIL: mbp.care@manthorpebp.co.uk
 WEB: www.manthorpebp.co.uk

KB

08/11/19

DRG No

ISSUE

The company maintains a policy of continuous development of its product range and reserves the right to amend the specification without notice.

MBP 8350

B