

Tile Ventilator Range - Flat Edge

CODE **GTV-FE**

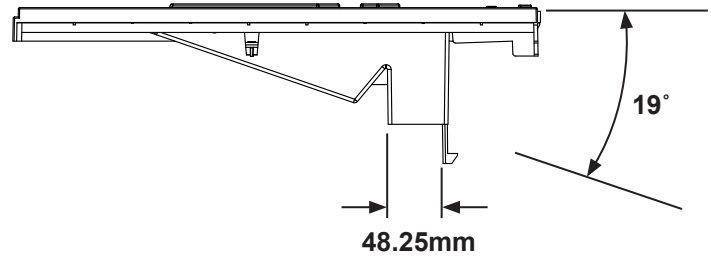
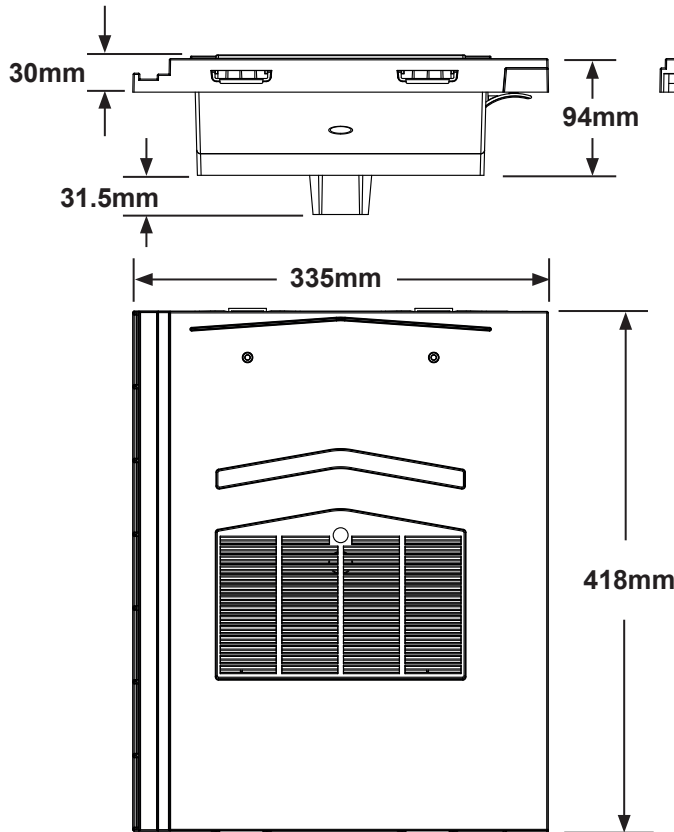

Description

The Manthorpe Flat Edge tile ventilator is designed to provide a quick and simple solution to the problems of roofspace ventilation and mechanical extraction / soil stack termination through a roof tiled with Calderdale Edge interlocking concrete tiles.

The flat vent is designed to replace a single tile and maintain an unbroken appearance to the roofline whether used at high or low level. The tortured path through the 4mm louvred grill and internal weathering geometry is designed to maintain a 10k mm² of airflow whilst channelling any water ingress out of the vent and on to the roof covering.

Part Weight	1.08 kg
Box Qty	4
Materials - Top Base	PVC Polypropylene
Colours	Terracotta, Grey, Black, Brown & Antique Red
Free Airflow	10,000 mm ² per unit

Features

- In-line and discreet low profile design.
- 4mm louvred flyscreen grill.
- Integral sidelock clip to ensure secure fit.
- Range of profiles and colours available.
- Profiles suit all top tile manufacturers.
- Fully independently wind tunnel tested.
- Base outlet feeds directly into roof space.
- Adaptor available for mechanical extraction.
- Suitable for use down to a 20° roof pitch.

References

BSI: BS 5250:2011 Control of Condensation in Building
 BSI: BS 5534:2014 Code of Practice for Slate and Tiling
 BSI: BS 490:2004 Concrete tiles and fittings for roof covering
 BRE: prEN 15601
 Building Regulations 2010
 NHBC: Good Craftmanship Guides

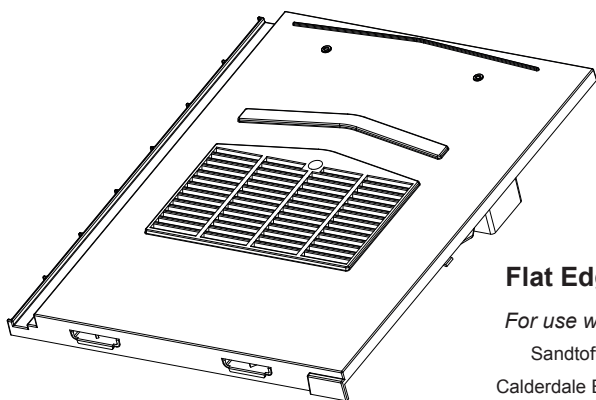

Flat Edge

For use with:
 Sandtoft
 Calderdale Edge

MANTHORPE BUILDING PRODUCTS LTD
 MANTHORPE HOUSE
 BRITAIN DRIVE
 CODNOR GATE BUSINESS PARK
 RIPLEY
 DERBYSHIRE DE5 3ND

TEL: 01773 303 000
 FAX: 01773 303 300
 EMAIL: mbp.care@manthorpebp.co.uk
 WEB: www.manthorpebp.co.uk

DRN B.H. Date 20.06.19

The company maintains a policy of continuous development of its product range and reserves the right to amend the specification without notice.

DRG No

MBP 8334

Issue

B