

Small Format In-Line Slate Ventilator

CODE **GILSV25-20**

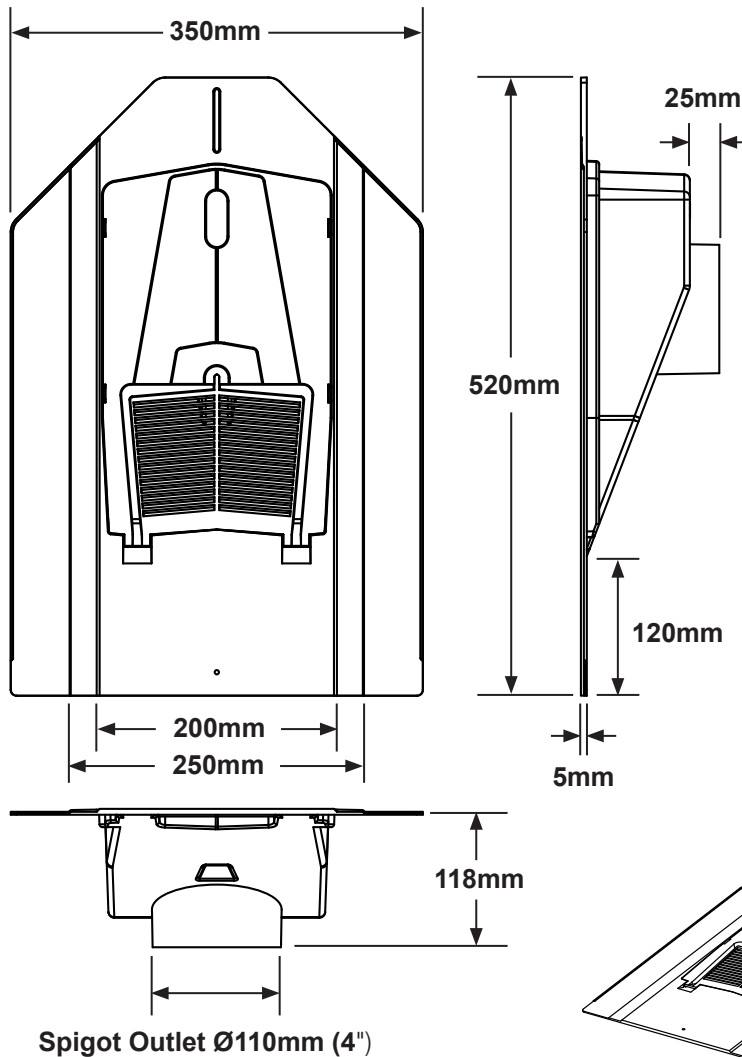

Description

The Manthorpe Small Format In-Line Slate Ventilator is designed to provide a quick and simple solution to the problems of roofspace and mechanical ventilation through a roof covered with natural or man-made slates.

The vent's flat profile with its lightly textured finish helps to maintain an unbroken appearance to the roofline whether used at high or low level. The tortured path through the 4mm louvred grill and internal weathering geometry is designed to maintain airflow whilst channelling any water ingress out of the vent and on to the roof covering.

The vent can be used with 500 x 250mm sizes slates down to 400 x 200mm coverings and various sizes in between.

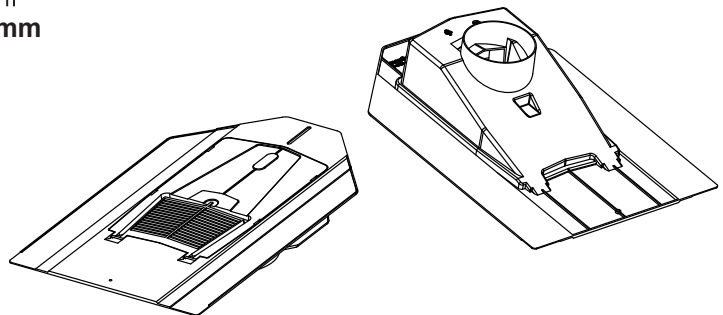

Part Weight	0.710 kg
Box Qty	10
Material	Polypropylene
Colours	Black, Grey
Free Airflow	6,000 mm ² per unit

References

BSI: BS 5250:2011 Control of Condensation in Building
 BSI: BS 5534:2014 Code of Practice for Slating and Tiling
 BRE: Tested to prEN 15601 (report P107103-1000)
 Building Regulations 2010
 NHBC: Good Craftsmanship Guides

Features

- In-line and discreet low profile design.
- Lightly textured surface finish
- 4mm louvred flyscreen grill.
- Protective edge laps improve weatherproofing
- Suits 500 x 250mm down to 400 x 200mm slates.
- Wind tunnel tested at the BRE (report P107103-1000)
- Integral 4" outlet feeds directly into roof space.
- Built-in pipe adaptor for mechanical extraction.
- Suitable down to a 22.5° pitch for 500 x 250 slates.
- Minimum pitch for use with 400 x 200 slates is 30°.

MANTHORPE BUILDING PRODUCTS LTD
 MANTHORPE HOUSE
 BRITAIN DRIVE
 CODNOR GATE BUSINESS PARK
 RIPLEY
 DERBYSHIRE DE5 3ND

TEL: 01773 303 000
 FAX: 01773 303 300
 EMAIL: mbp.care@manthorpebp.co.uk
 WEB: www.manthorpebp.co.uk

DRN B.H. Date 20.06.19

DRG No

Issue

The company maintains a policy of continuous development of its product range and reserves the right to amend the specification without notice.

MBP 8324

B