

In-Line Slate Ventilator

CODE **GILSV30-25**

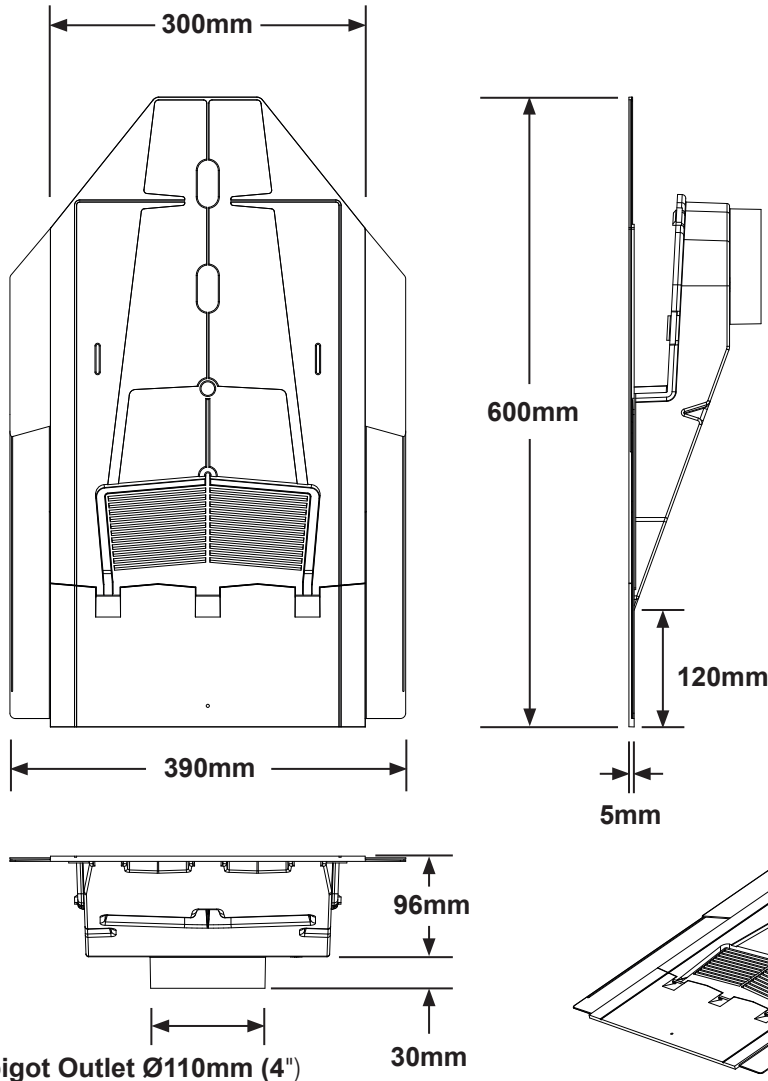

Description

The Manthorpe In-Line Slate Ventilator is designed to provide a quick and simple solution to the problems of roofspace ventilation and extraction through a roof covered with natural or man-made slates.

The vents flat profile with it's lightly textured finish helps to maintain an unbroken appearance to the roofline whether used at high or low level.

The tortured path through the 4mm louvred grill and internal weathering geometry is designed to maintain airflow whilst channelling any water ingress out of the vent and on to the roof covering.

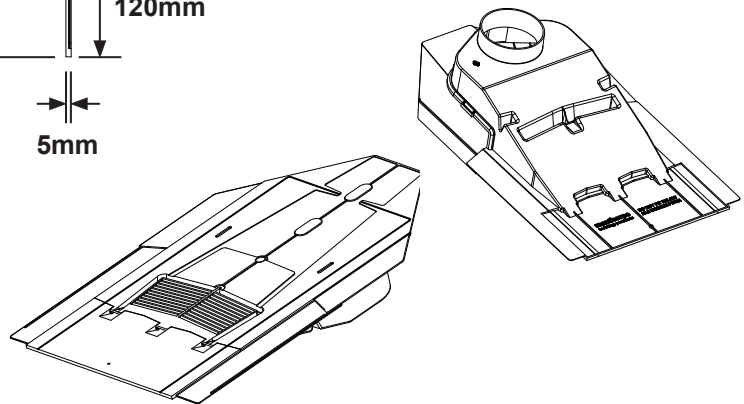

Spigot Outlet Ø110mm (4")

Part Weight	0.883 kg
Box Qty	10
Material	Polypropylene
Colours	Black, Grey
Free Airflow	8,800 mm ² per unit

References	
BSI: BS 5250:2011 Control of Condensation in Building	
BSI: BS 5534:2014 Code of Practice for Slating and Tiling	
BRE: Tested to prEN 15601 (report no. BP137758)	
Building Regulations 2010	
NHBC: Good Craftsmanship Guides	

Features	
<ul style="list-style-type: none"> • In-line and discreet low profile design. • Lightly textured surface finish • 4mm louvred flyscreen grill. • Protective edge laps improve weatherproofing • Suits 600 x 300mm slates (500 x 250mm by trimming slates). • No batten cutting required for larger format slates. • Wind tunnel tested at the BRE (report BP137758) • Integral 4" outlet feeds directly into roof space. • Built-in pipe adaptor for mechanical extraction. • Suitable for use down to a 22.5° roof pitch. 	

MANTHORPE BUILDING PRODUCTS LTD
 MANTHORPE HOUSE
 BRITAIN DRIVE
 CODNOR GATE BUSINESS PARK
 RIPLEY
 DERBYSHIRE DE5 3ND

TEL: 01773 303 000
 FAX: 01773 303 300
 EMAIL:
 mbp.care@manthorpebp.co.uk
 WEB
 www.manthorpebp.co.uk

DRN B.H. Date 20.06.19
 The company maintains a policy of continuous development of its product range and reserves the right to amend the specification without notice.

DRG No
MBP 8312

Issue
E