

**Flexi Pipe
Adaptor
GTV-AD**

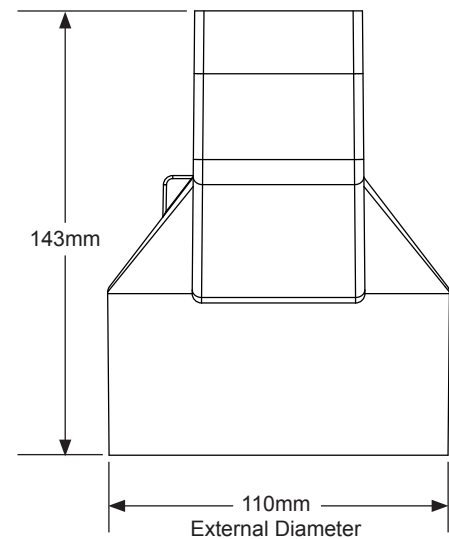
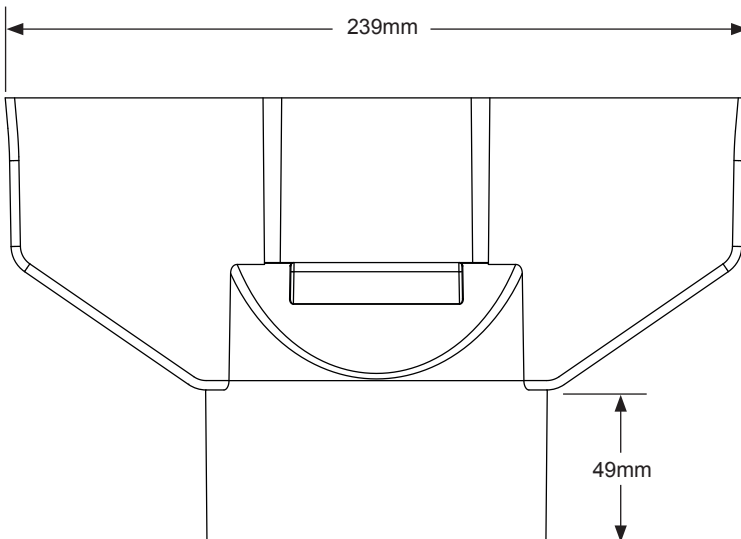
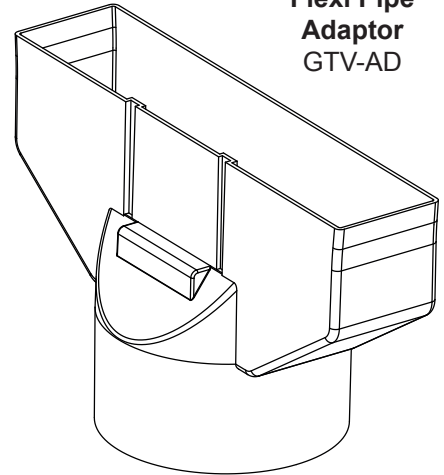
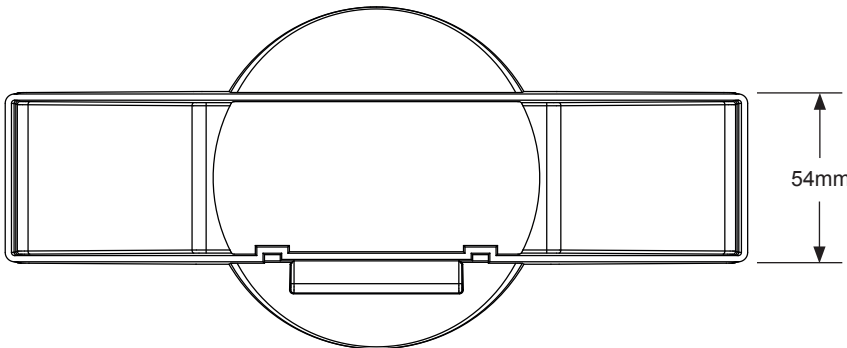

Description

The Manthorpe range of in-line tile ventilators can also be used as outlet terminals for extraction fans and soil pipe ventilation when used in conjunction with a Manthorpe Flexi Pipe Adaptor GTV-AD and one of the range of GRPA Flexible Pipes. This will convert the rectangular vent outlet to a 4 inch diameter pipe opening.

| | |
|------------------------------|-----------------------|
| Packing Details | 10 per box |
| Material | Polypropylene |
| Colour | Black |
| Manufacturing Process | Injection Moulded |
| Free Airflow | 8,800 mm ² |

MANTHORPE BUILDING PRODUCTS LTD
MANTHORPE HOUSE
BRITAIN DRIVE
CODNOR GATE BUSINESS PARK
RIPLEY
DERBYSHIRE DE5 3ND

TEL: 01773 303 000
FAX: 01773 303 300
EMAIL:
mbp.care@manthorpebp.co.uk
WEB
www.manthorpebp.co.uk

DRN B.H. Date 19.06.19

The company maintains a policy of continuous development of its product range and reserves the right to amend the specification without notice.

DRG No

MBP 8297

Issue

F

1 of 2

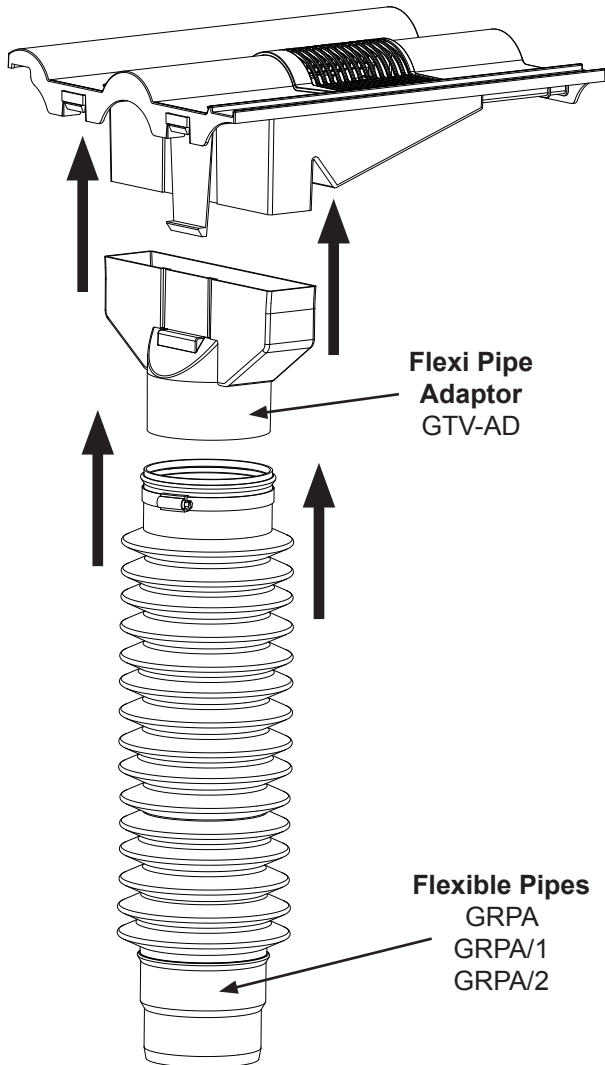

Fitting Instructions

The GTV-AD can be fitted to a Manthorpe tile ventilator before it is installed or can be attached later from within the loft space, with the exception of the GTV-PT Plain Tile Vent, with which you can only fit the adaptor from inside the loft.

- 1) To attach the adaptor to the tile ventilator, align the rectangular opening of the GTV-AD with the outlet on the base of the vent.
- 2) Firmly push the GTV-AD over the outlet, ensuring the clip feature slots inside the adaptor, until it reaches the stops on the vent's base moulding.
- 3) At this point the clip should locate itself over the internal ledge of the GTV-AD to lock it in position.
- 4) If attaching the adaptor first, the tile vent can now be installed as usual, making sure the adaptor is carefully fed through the opening in the felt into the roof space.
- 5) From inside of the roof space, connect a length of 4 inch diameter flexible ducting or use one of the Manthorpe Flexi Pipes to directly fix onto the outlet of the adaptor. When using a GRPA pipe, push the end marked "A" securely over the outlet and secure in place with the supplied jubilee clip.
- 6) To connect the GRPA7 range to an extraction fan terminal or soil stack, feed the end marked "B" inside the desired outlet pipe. To form an air or fully water tight seal to soil stacks it may be necessary to apply an additional jubilee clip (not supplied), mastic sealant or to tape the joint.

NOTE: To comply with the BRE Report 262, it is recommended that the GRPA pipes and other ducting should be fully insulated along its total length in the roof space to avoid the risk of internal condensation.

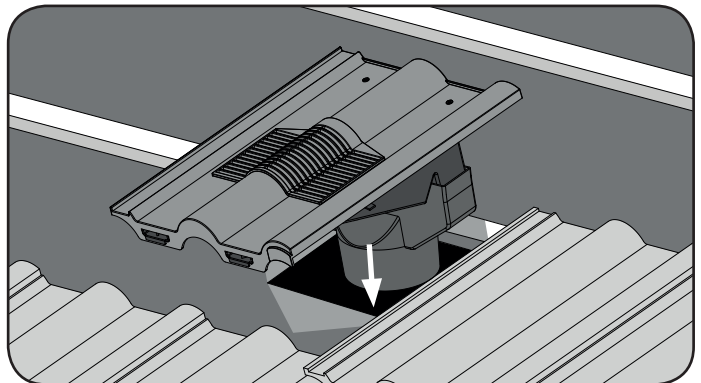

MANTHORPE BUILDING PRODUCTS LTD
MANTHORPE HOUSE
BRITAIN DRIVE
CODNOR GATE BUSINESS PARK
RIPLEY
DERBYSHIRE DE5 3ND

TEL: 01773 303 000
FAX: 01773 303 300
EMAIL: mbp.care@manthorpebp.co.uk
WEB
www.manthorpebp.co.uk

DRN B.H. Date 19.06.19

The company maintains a policy of continuous development of its product range and reserves the right to amend the specification without notice.

DRG No

MBP 8297

Issue

F
2 of 2