

Airbrick Flood Defence Frame

CODE G980

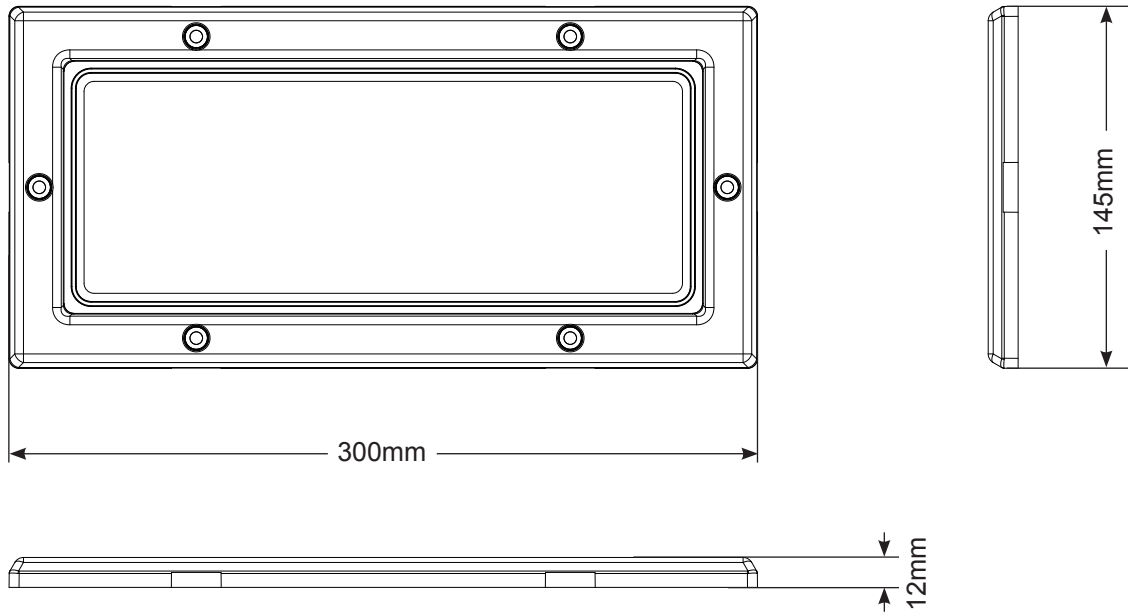

Description

The mounting frame for the Airbrick Flood Defence is designed to be as a permanent installation around a 9"x3" airbrick, to then be used as a means of attaching the removable cover over to block out flood waters. There is a channel on the back of the frame to run a thick bead of exterior frame sealant around to seal the frame to the wall, preventing ingress of water. The frame is secured into the wall by screws into the surrounding brickwork which can then be covered with the caps provided. The frame is available in a variety of colours to match most types of wall covering.

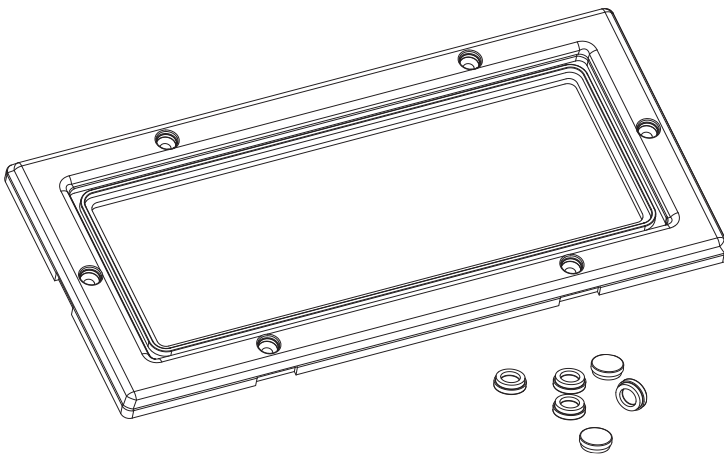

Specification

Colours - Frame	Brown Terracotta Blue/Black	Buff Grey White
Packing Details	Sealed in a bag with fitting instructions, 10 units in a box	
Weight	0.071kg	
Material	Polypropylene	
Manufacturing Process	Injection moulded	

MANTHORPE BUILDING PRODUCTS LTD
MANTHORPE HOUSE
BRITAIN DRIVE
CODNOR GATE BUSINESS PARK
RIPLEY
DERBYSHIRE DE5 3ND

TEL: 01773 303 000
FAX: 01773 303 300
EMAIL:
mbp.care@manthorpebp.co.uk
WEB
www.manthorpebp.co.uk

DRN B.H. Date 19.06.19

The company maintains a policy of continuous development of its product range and reserves the right to amend the specification without notice.

DRG No

MBP 8279

Issue

B