

3 Metre Roll-Out Dry Ridge System - Overview

CODE **GDRR-3M**

Description

The Manthorpe Roll-Out Dry Ridge is a mechanically fitted system which securely fixes the ridge tiles on to a roof and provides 5,000mm²/m ventilation to the batten void or roof space through the vent roll, which is the equivalent to a continuous 5mm gap.

Due to the nature in which the system is fitted, there is no need for mortar, making the job of fixing the ridge quick, easy, and clean, as well as making it possible during frosts and other adverse weather conditions.

The system is compatible with most makes of concrete ridge tiles, both round and angled and can be fitted onto most slate, clay and concrete roof covering, including profiled tiles. The product is designed to be fitted to the ridge of any duo pitch roof which has a pitch between 15 and 45 degrees.

The system is available in 2 different colours (Black and Dark Brown) and can be used in conjunction with Manthorpe's Ridge End Caps and both their SmartVerge and Linear Dry Verge systems.

Specifiers should ensure that dry fix roofing systems are compatible with their detail prior to installation.

Independently tested to conform with the requirements of BS 8612.

3 Metre Vent Roll

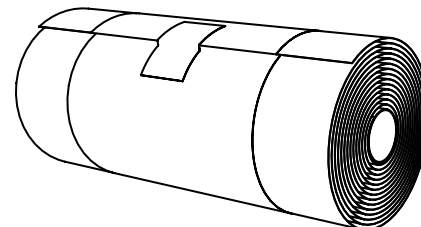

Ridge Union

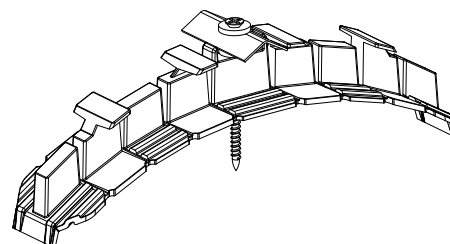

Batten Support Bracket

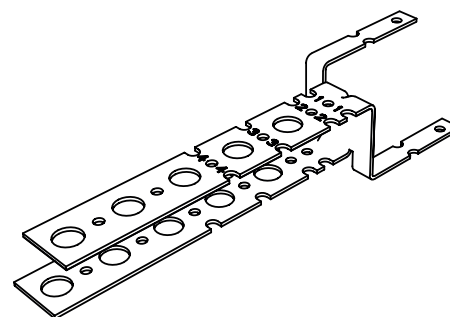

Features:

- A dry fix mechanical fixing, securely fixes the ridge tiles without the need for mortar and pointing.
- Vented ridge roll provides a 5,000mm²/m of airflow.
- Independently wind tunnel tested by the BRE.
- One box provides all of the components required for a 3 metre ridge run (excluding the ridge tiles).
- Compatible with most makes of concrete ridge tiles, both round and angled.
- Designed for use on roofs with pitches between 15° & 45°.
- The system can be fitted onto most slate, clay and concrete roof coverings, including profiled tiles.
- Quick and easy to fix with no special tool requirements.
- Available in 2 different colours (Black and Dark Brown)
- Ridge ends can be finished off with Manthorpe's Ridge End Caps, available from their dry verge range.

GDRR System Pack Quantities

x1 3 metre Vent Roll

x7 Ridge Unions

x5 Batten Support Brackets.

BS 8612 Specifications

- Profile class compatibility: **Low** (≥ 1.15 Expansion)
High (≥1.30 Expansion)
- Provides a measured geometric free area of 5,000mm²/M.
- Performance data for the tests conducted on this product is available upon request.

References

BSI: BS 5534:2003
 BSI: BS 5250:2011
 BSI: BS EN 1991-1-4:2005+A1:2010
 BSI: BS 8612:2018
 NHBC Standards Chapter 7.2

MANTHORPE BUILDING PRODUCTS LTD
 MANTHORPE HOUSE
 BRITAIN DRIVE
 CODNOR GATE BUSINESS PARK
 RIPLEY
 DERBYSHIRE DE5 3ND

TEL: 01773 303 000
 FAX: 01773 303 300
 EMAIL: mbp.care@manthorpebp.co.uk
 WEB: www.manthorpebp.co.uk

DRN K.B

Date 20/06/19

DRG No

Issue

The company maintains a policy of continuous development of its product range and reserves the right to amend the specification without notice.

MBP 8313

C