

Manthorpe

GLTAP-500 Tile Access Panel

Fixing Instructions

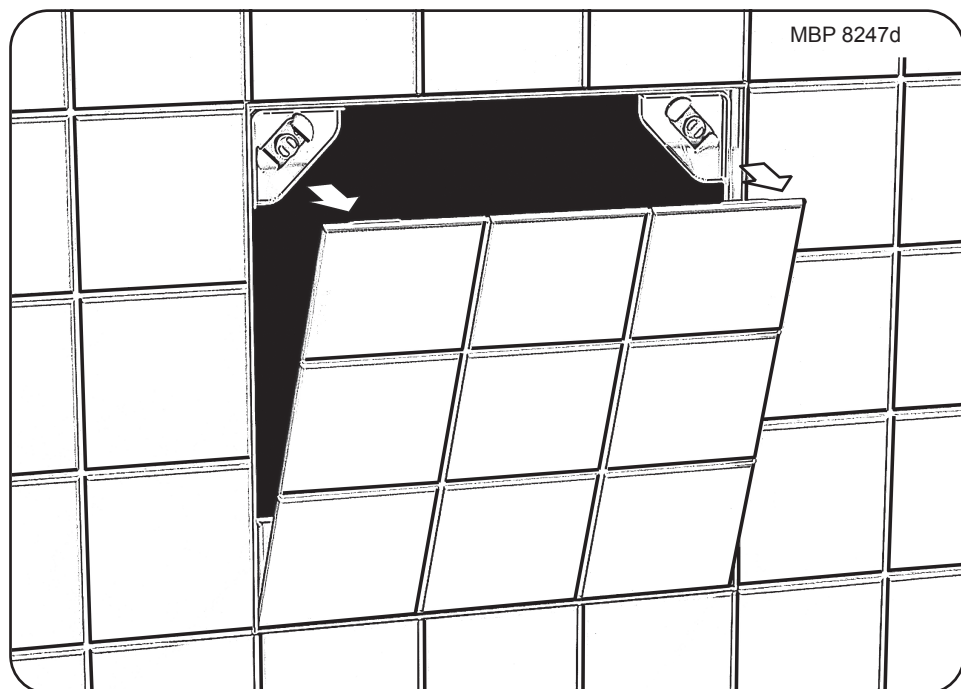

Preparation

The minimum and maximum size of the Tile Access Panel must not exceed the following weight and dimensions: -

Variable Dimension: **Minimum Opening = 150mm x 150mm**
 Maximum Opening = 500mm x 500mm (or equivalent area)

Max. Weight of Panel: **2.8 kg**

For rectangular openings, use the following graph to calculate the maximum opening size for the Tile Access Panel: -

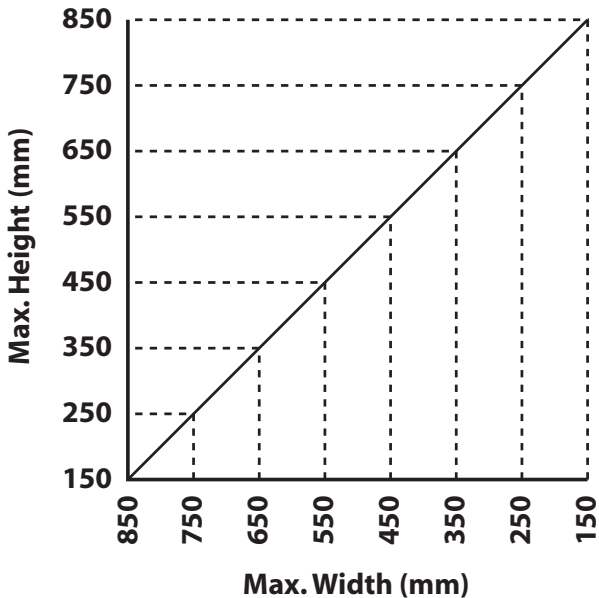

Contents

The GLTAP-5CP Tile Access Panel contract pack contains: -

- | | |
|------------------------------|-------------------------------------|
| 1. Corner Part No. 1 (LH) x5 | 7. Corner Part No. 7 (LH) x5 |
| 2. Corner Part No. 2 (RH) x5 | 8. Corner Part No. 8 (RH) x5 |
| 3. Corner Part No. 3 (LH) x5 | 9. Magnetic Touch Latches x10 |
| 4. Corner Part No. 4 (RH) x5 | 10. Frame Extrusion 10 x 1m lengths |
| 5. Corner Part No. 5 (LH) x5 | 11. Fixing Instructions x1 |
| 6. Corner Part No. 6 (RH) x5 | |

The Tile Access Panel is designed for use with **6mm** thickness, water-resistant tile backerboard (not included).

The Complete System

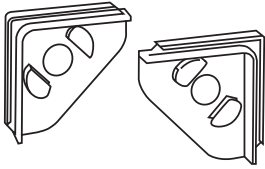

Corner Parts 1 & 2
(5 Pairs)

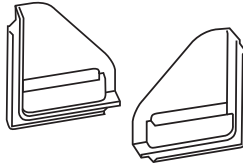

Corner Parts 3 & 4
(5 Pairs)

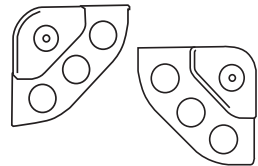

Corner Parts 5 & 6
(5 Pairs)

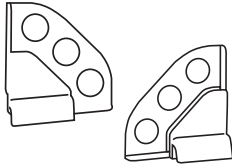

Corner Parts 7 & 8
(5 Pairs)

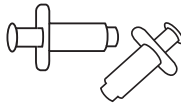

Magnetic Touch
Latches (5 Pairs)

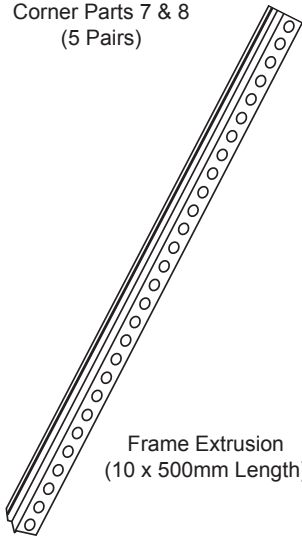

Frame Extrusion
(10 x 500mm Length)

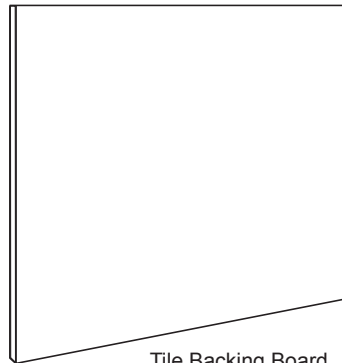

Tile Backing Board
(x1)

Other products from the Manthorpe Range include Cavity Trays, Lintel Trays, Cavity Closer, Loft Doors, Roof Ventilation, Through Wall Ventilation, Joist Seals and Drainage Channels.



Manthorpe Building Products Limited

Manthorpe House, Brittain Drive, Codnor Gate Business Park, Ripley, Derbyshire DE5 3ND

T: (01773) 303 000 F: (01773) 303 300 E: mbp.care@manthorpebp.co.uk

W: <http://www.manthorpebp.co.uk>

Installation

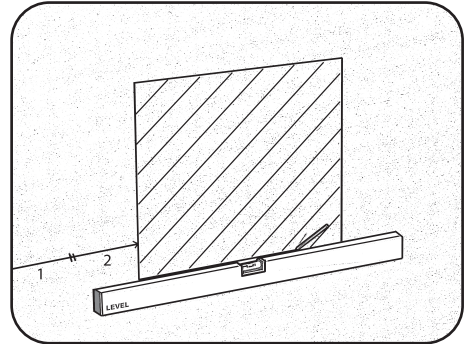
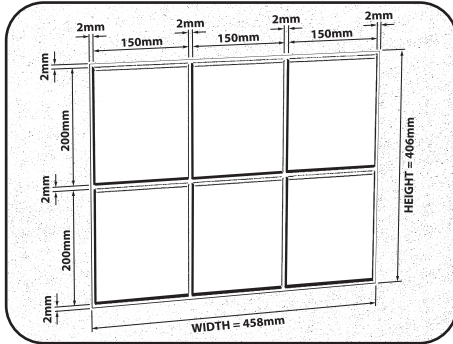

1. Calculate the total height and width of the access panel opening by measuring all tiles including separating and surrounding grout joints.

Example: Tiles = 150mm x 200mm
Panel = 3 tiles x 2 tiles
Grout width = 2mm
Opening = 458mm x 406mm

2. Mark out the opening, making sure it is square and level with a spirit level. (It may be worth calculating the distance of the opening from the outer edge of the wall and floor to avoid the need for cutting tiles when you come to tiling the perimeter of the wall).

Cut out the opening using a suitable knife or saw.

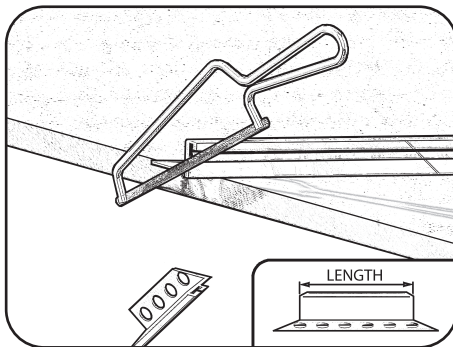

3. Saw four lengths of extrusion at 45° using a mitre saw or suitable hand saw to form a frame, equal in size to your opening.

Note: measure and saw on the outside face of the frame as shown, NOT the perforated flange.

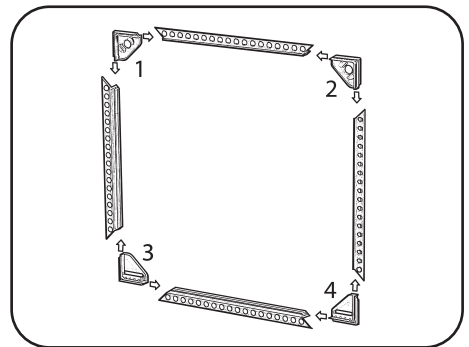

4. Assemble the frame with corner parts 1, 2, 3 and 4 as shown by sliding the 'T' section of the corner clips into the 'C' section of the extrusion.

Once assembled, ensure the frame is square and of equal size to your opening.

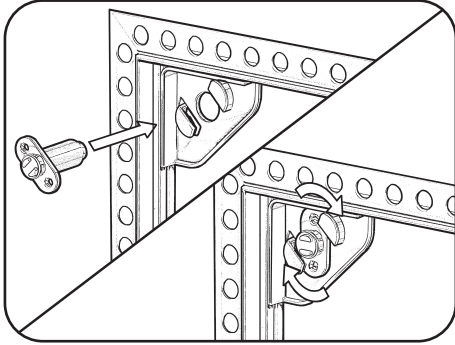

5. Assemble both magnetic touch latches to the frame by inserting them into corner parts 1 and 2 as shown then twisting 90° clockwise until both latches “click” into place.

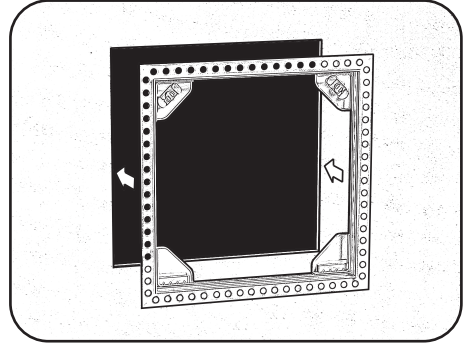

6. Push the assembled frame firmly into the wall opening so that the perforated flange sits tightly against the wall.

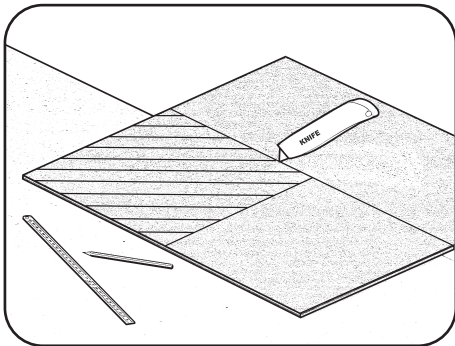

7. Using the tile backing board provided, mark out a panel 25mm smaller in both height and width than the wall opening.

Example:

If wall opening = 458mm x 406mm

Backing board = 433mm x 381mm

Cut the panel down to size using a suitable cutting tool.

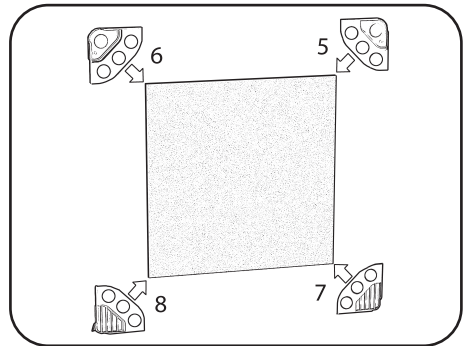

8. Attach the plastic corner parts 5, 6, 7 and 8 to the backing board as shown so that they sit firmly against the edges of the board.

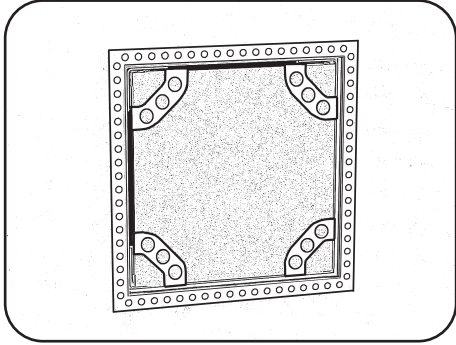

9. Insert the panel into the frame by engaging both hinges and then pushing the magnets together.

Test the size of the panel in relation to the frame by opening and closing it a few times, ensuring both the frame and panel are the correct size.

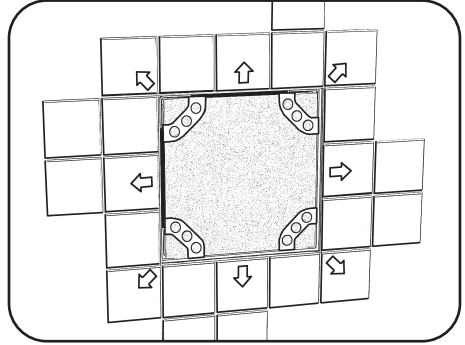

10. Using standard tiling practices, tile the wall outside of the frame.

Always start from the frame and work outwards to the edge of the wall. Ensure the frame is securely bonded between the tiles and the wall using tile adhesive.

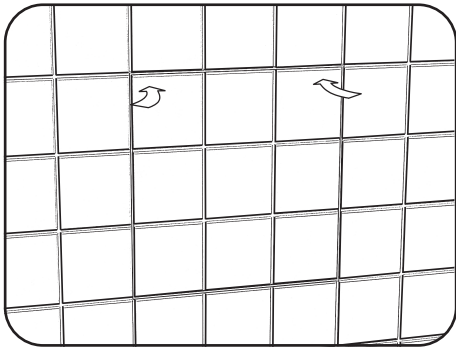

11. Tile the front of the panel leaving a thin gap between the outer tiles and the frame to allow the panel to open.

Once the tiles are in place, allow to dry for 24 hours before removing the access panel from the wall. Grout both the panel and the surrounding wall separately.

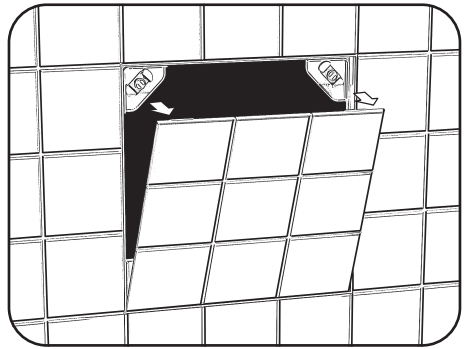

12. The Tile Access Panel is now ready to be used.

To access it, push on both top corners and allow the panel to release while supporting the door.