

PRODUCT DESCRIPTION

The Manthorpe range of Lintel Trays are fabricated in three different sizes to suit cavity widths up to 150mm and lintel heights of 230mm, they are available in rolled lengths of 5 & 25 meters. Its pre-creased design enables the tray to be folded to suit a variety of lintels profiles and its rigidity allows it to be self supporting. This eliminates the need to build into the inner leaf wall.

Manthorpe's Lintel Trays are designed in response to NHBC and British Standard requirements. These state that cavity tray/dampproof protection should be provided over all openings.

The Lintel Tray is made of tough, durable polypropylene and will protect cavity wall lintels against corrosion from moisture. Any water collects on the top of the lintel tray and is contained by the stop ends. The water is then directed to the outside of the building through Peep or Weep Vents in the outer cavity.

SPECIFICATION	
COLOUR	BLACK
TEXTURE	TEXTURED FINISH
MATERIAL	POLYPROPYLENE
MANUFACTURING PROCESS	FABRICATED
PACKAGING	LENGTHS ROLLED & PACKED INTO POLYTHENE BAG

REFERENCES	
BSI	BS5268
NHBC	STANDARDS 6.1

COMPATIBILITY
Compatible with most Lintel Manufactures

MANTHORPE BUILDING PRODUCTS LTD MANTHORPE HOUSE BRITTAIN DRIVE CODNOR GATE BUSINESS PARK RIPLEY DERBYSHIRE DE5 3ND	TEL: 01773 303 000 FAX: 01773 303 300 EMAIL: mbp.care@manthorpebp.co.uk WEB: www.manthorpebp.co.uk	DRN P.S	DATE 26.06.19	DRG NO	ISSUE
		The company maintains a policy of continuous development of its product range and reserves the right to amend the specification without notice.		MBP 8243 (PAGE 1 OF 2)	D

Lintel Tray

Code: GW281, GW282, GW283

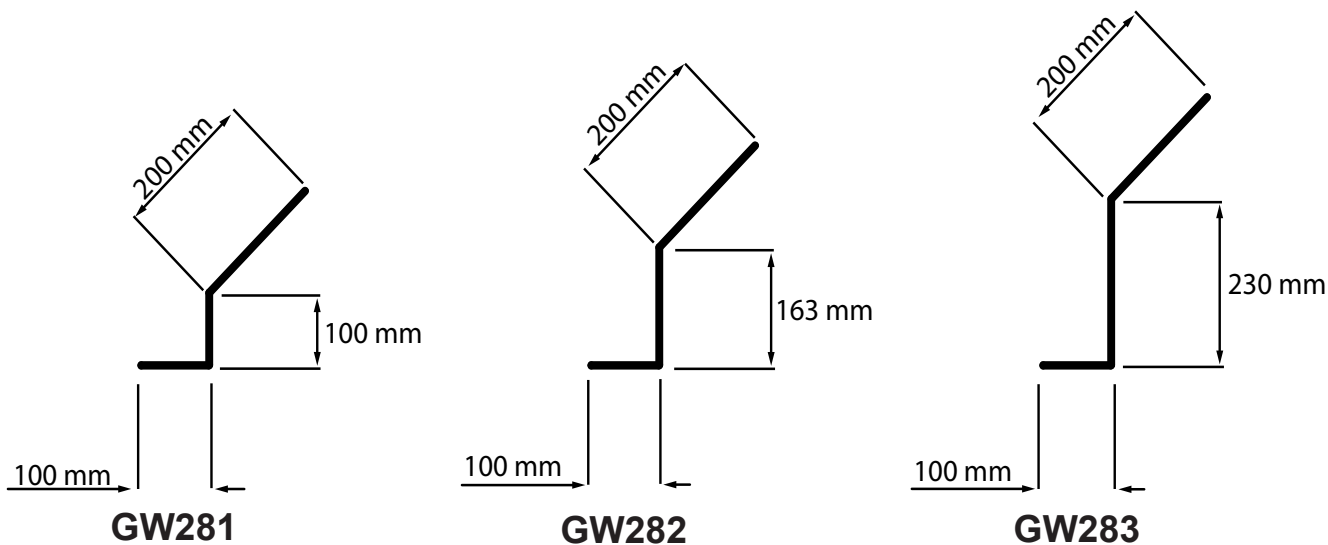

PRODUCT CODE	PRODUCT HEIGHT	PRODUCT LENGTH	PRODUCT WEIGHT
GW281-5	400MM	5 METERS	1.5 KG
GW281-25	400MM	25 METERS	8.0 KG
GW282-5	463MM	5 METERS	2.0 KG
GW282-25	463MM	25 METERS	10.0 KG
GW283-5	530MM	5 METERS	2.5 KG
GW283-25	530MM	25 METERS	11.5 KG

Manthorpe Lintel Trays should be used with the following products:

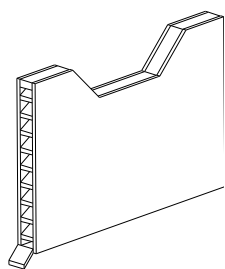

Weep Vent
(Code: G950)

Lintel Stop End
(Code: G955)

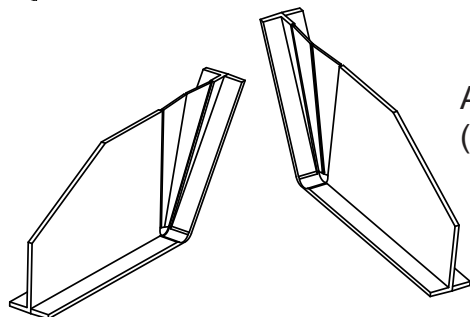
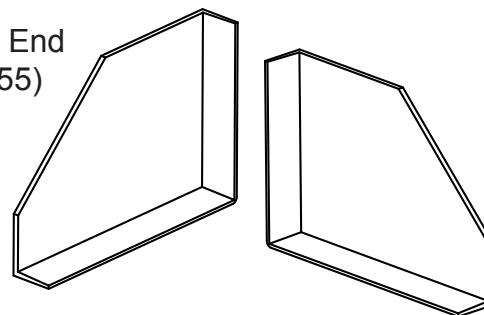

Adjustable Lintel Stop End
(Code: G956)

Peep Weep
(Code: G953)

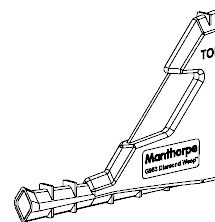

MANTHORPE BUILDING PRODUCTS LTD
MANTHORPE HOUSE
BRITAIN DRIVE
CODNOR GATE BUSINESS PARK RIPLEY
DERBYSHIRE DE5 3ND

TEL: 01773 303 000
FAX: 01773 303 300
EMAIL:
mbp.care@manthorpebp.co.uk
WEB:
www.manthorpebp.co.uk

DRN P.S DATE 26.06.19

The company maintains a policy of continuous development of its product range and reserves the right to amend the specification without notice.

DRG NO

MBP 8243
PAGE (2 OF 2)

ISSUE

D