

Sloping Soffit Ventilator

CODE **G821**

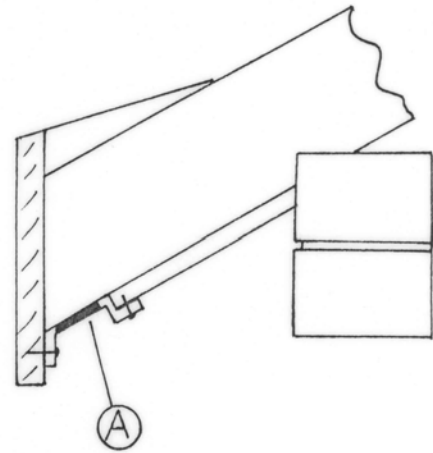
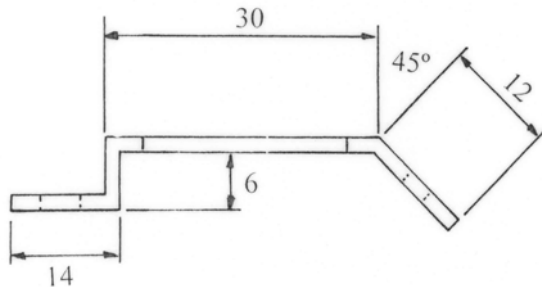
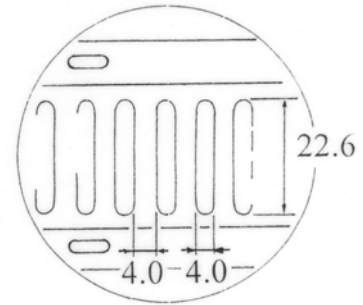
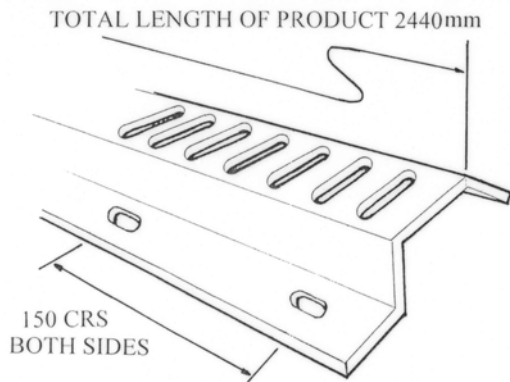

Description:

The G821 Sloping Soffit Ventilator is designed to provide the solution to ventilation for sloping eaves. The angled section ensures a positive fixing to the soffit board and prevents blocking of the ventilation.

The airflow passage consists of evenly spaced slots specifically sized to prohibit large insects gaining access but wide enough not to be blocked by debris, paint or water droplets (See BS5250 section 6).

Fitting Instructions:

The soffit board should be cut 32mm short of the fascia board and fixed as normal.

The G821 Sloping Soffit Ventilator (A) should be securely screwed to the soffit board through the stepped mouth, and onto the fascia board using the fixing holes provided as shown.

Use in conjunction with other products from the Manthorpe range to provide a complete roof ventilation system.

COLOURS	White, Brown,
PACKING DETAILS	Packed in 10's in poly sleeve.
WEIGHT	2.8kg per pack
MATERIAL	UPVC
MANUFACTURING PROCESS	Extrusion
FREE AIRFLOW	10,000mm ² /M equivalent to a continuous gap of 10mm

References:

BRE:	DIGEST 262/270
BSI:	BS5250
DOE:	Building Regs F2
NHBC:	Good Practice Guide
NHBC:	Standards 7.2

MANTHORPE BUILDING PRODUCTS LTD
MANTHORPE HOUSE
BRITAIN DRIVE
CODNOR GATE BUSINESS PARK
RIPLEY
DERBYSHIRE DE5 3ND

TEL: 01773 303 000
FAX: 01773 303 300
EMAIL: mbp_care@manthorpebp.co.uk
WEB: www.manthorpebp.co.uk

DRN M.A Date 20.06.19

The company maintains a policy of continuous development of its product range and reserves the right to amend the specification without notice.

DRG No

MBP 8003

Issue

B