

Continuous Soffit Ventilator

CODE **G825**

TOTAL LENGTH OF PRODUCT 2440mm

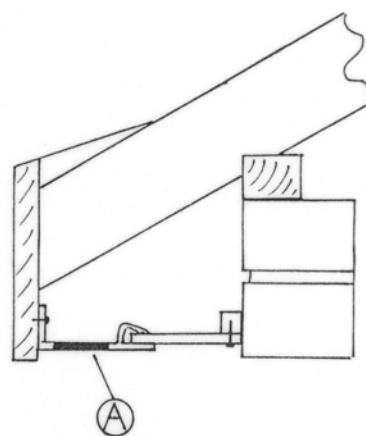
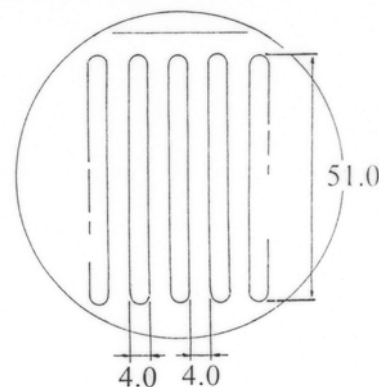
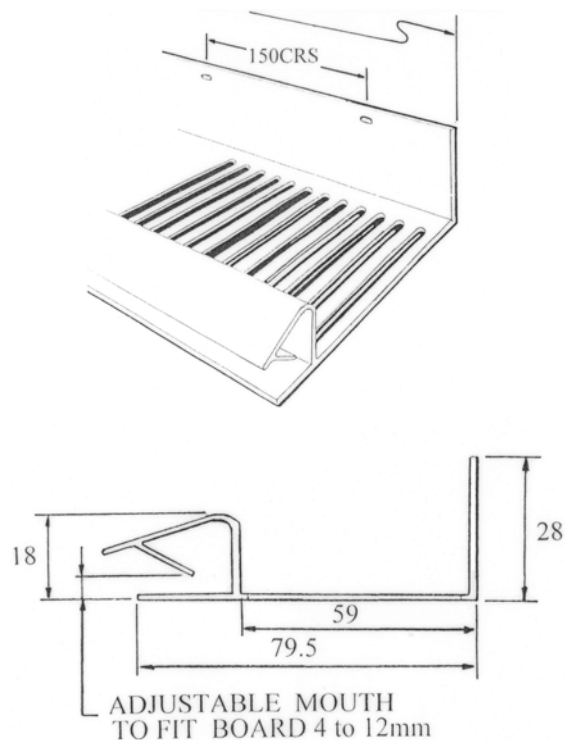

Description:

The G825 Continuous Soffit Ventilator is designed to provide a solution to roof ventilation where a traditional soffit board is specified and 25mm of air flow is required.

The airflow passage consists of evenly spaced slots specifically sized to prohibit large insects gaining access but wide enough not to be blocked by debris, paint or water droplets (See BS5250 section 6).

Fitting Instructions:

The G825 Soffit Ventilator (A) should be securely screwed to the soffit board through the fixing holes provided as shown.

The soffit board (4mm – 12mm) should be pushed into the adjustable mouth of the soffit strip and fixed to the brick course as normal.

Use in conjunction with other products from the Manthorpe range to provide a complete roof ventilation system.

COLOURS	White, Brown,
PACKING DETAILS	Packed in 10's in poly sleeve.
WEIGHT	7.6kg per pack
MATERIAL	UPVC
MANUFACTURING PROCESS	Extrusion
FREE AIRFLOW	25,000mm ² /M equivalent to a continuous gap of 25mm

References:

BRE:	DIGEST 262/270
BSI:	BS5250
DOE:	Building Regs F2
NHBC:	Good Practice Guide
NHBC:	Standards 7.2

MANTHORPE BUILDING PRODUCTS LTD
MANTHORPE HOUSE
BRITAIN DRIVE
CODNOR GATE BUSINESS PARK
RIPLEY
DERBYSHIRE DE5 3ND

TEL: 01773 303 000
FAX: 01773 303 300
EMAIL: mbp.care@manthorpebp.co.uk
WEB: www.manthorpebp.co.uk

DRN M.A Date 20.06.19

The company maintains a policy of continuous development of its product range and reserves the right to amend the specification without notice.

DRG No

MBP 8002

Issue

B