

## Hip Details

Fig A. Assembly View of Dry Hip Detail

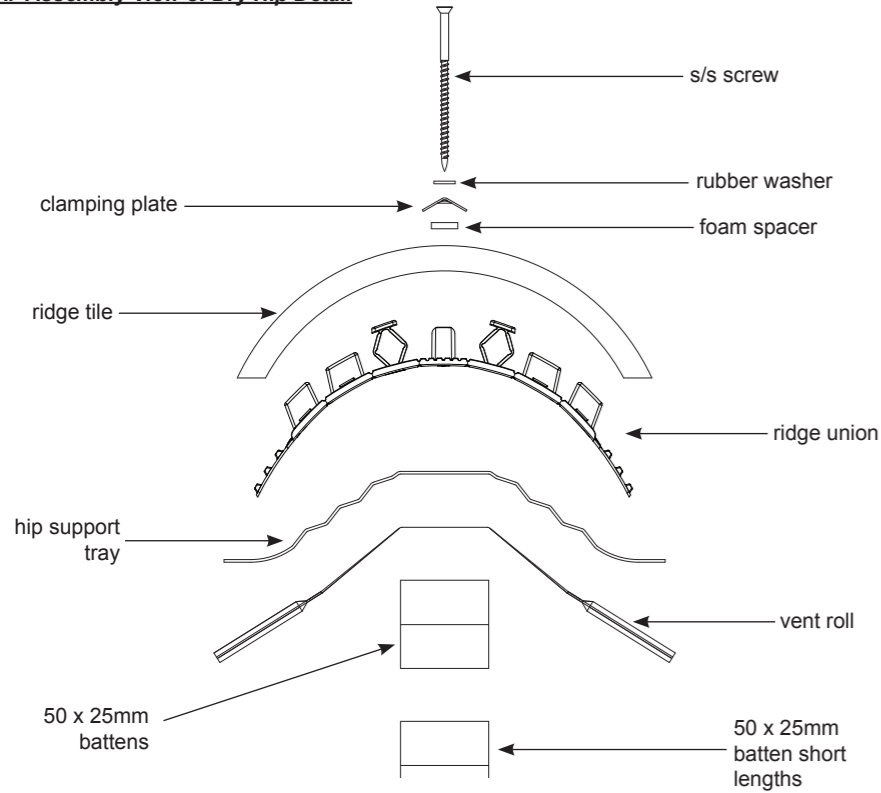
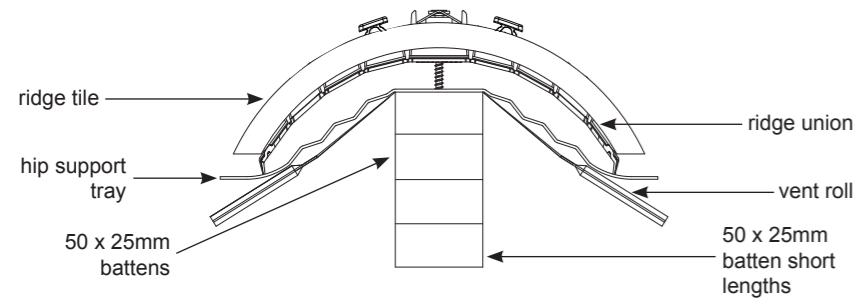
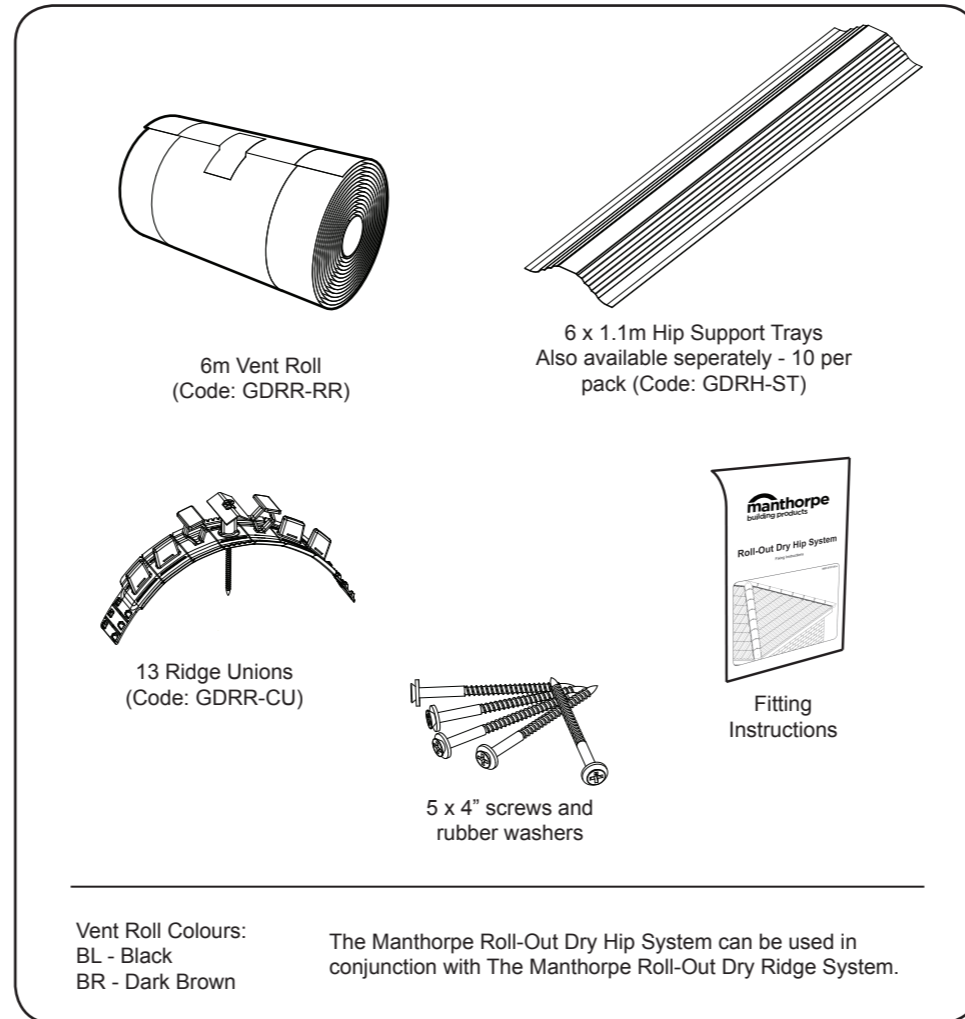

Fig B. Finished Dry Hip Detail



## The Complete System



Other products from Manthorpe include Cavity Trays, Cavity Closer, Loft Doors, Linear Drainage, Access Panels, Roof Ventilation, Through Wall & Underfloor Ventilation, Joist Seals and Dry Roofing Products.



### Manthorpe Building Products Limited

Manthorpe House, Brittain Drive, Codnor Gate Business Park, Ripley, Derbyshire DE5 3ND  
T: (01773) 303 000 F: (01773) 303 300 E: mbp.care@manthorpebp.co.uk  
W: <http://www.manthorpebp.co.uk>

# Manthorpe

## GDRH-CL

## Roll-Out Clay Hip System

Fixing Instructions

MBP1125-C

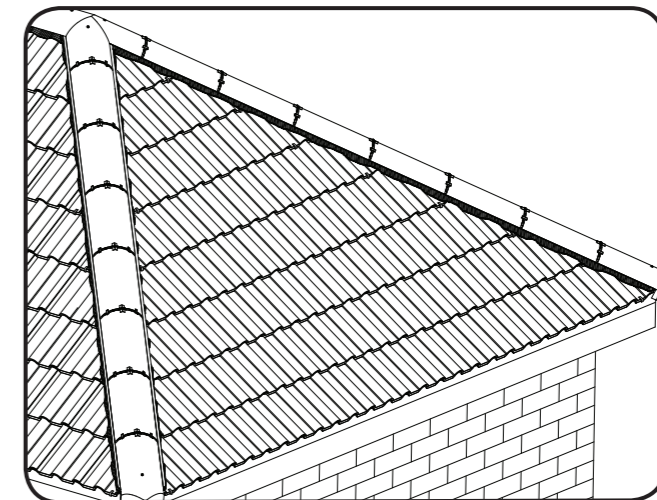

### BS 8612 Specifications

Profile class:

- ✓ **Low** ( $\geq 1.15$  Expansion)
- ✓ **High** ( $\geq 1.3$  Expansion)

Provides a measured geometric free area of

**5,000mm<sup>2</sup>/M**

As per the requirements of BS 5250

Independently tested to conform with the requirements of BS 8612.  
Performance data for the tests conducted on this product is available upon request.

## Overview

The Manthorpe Roll-Out Dry Hip System provides a quick, easy and neat solution to the fixing of tiles down the hip of a roof without the need for mixing and carrying mortar.

Designed as a universal system, the Manthorpe Dry Hip can be used with most makes of concrete hip tiles; both round and angled, and can be fitted onto most slate, clay and concrete roof coverings, including profiled tiles. It will also work on most pitches and plan angles of roof (for minimum and maximum pitch figures of particular tile and slate types, see tile manufacturer's literature).

The hip tray provided ensures an even and straight hip line on even the deepest tile profiles and is recommended for use with all roof coverings.

Specifiers should ensure that dry fix roofing systems are compatible with their detail prior to installation.

## Installation

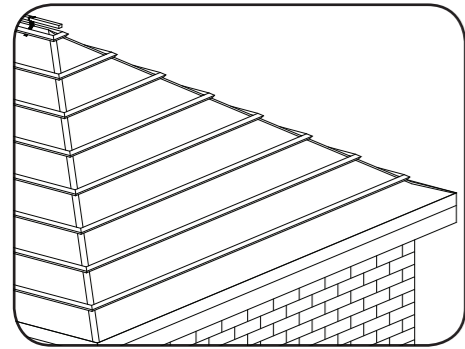

**1.** Prepare the roofing underlay in the traditional manner, dressing it over and around each hip detail.

Neatly mitre each of the battens at the change of angle and secure them onto the hip rafter.

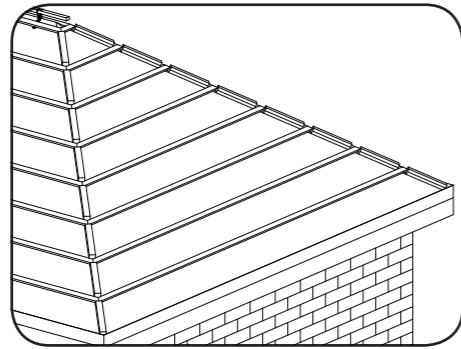

**2.** Cut lengths of 50 x 25mm batten to fit directly onto the hip rafter, between the tiling battens. Layer the pieces two high creating 50 x 50mm batten spacers and screw securely to the hip rafter.

Batten spacers need to be fitted at the eaves and the apex and at appropriate intervals up the hip rafter.

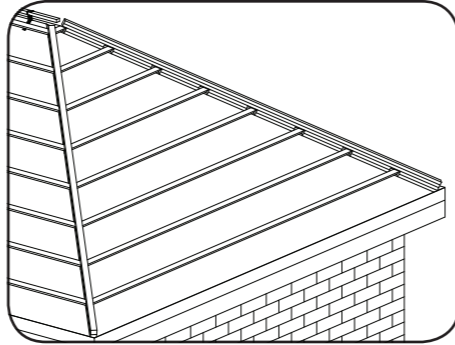

**3.** Lay lengths of 50 x 25mm batten cut to the length of the hip rafter on top of the batten spacers and screw the hip batten securely to them.

The hip batten can be built up with additional lengths of batten depending on the height required for the type of tiles being used.

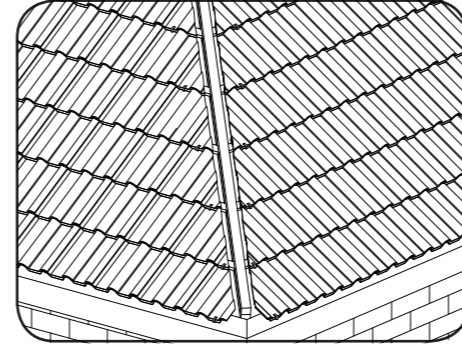

**4.** Tile the roof on both sides of the hip as normal.

Make sure no cut is more than 30mm from the hip batten. Secure smaller cuts of tiles using tile clips available from the tile manufacturer.

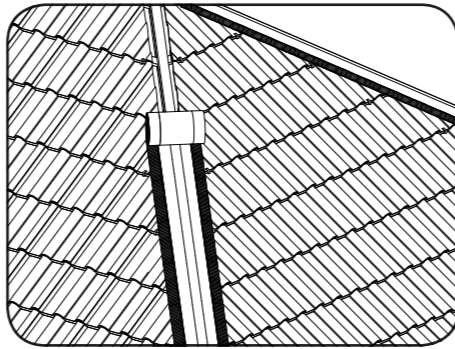

**5.** Starting at the eaves roll out the Vent Roll centrally along the entirety of the hip. Neatly trim the roll at the eaves and at the ridge allowing the roll to overlap the ridge apex by 100mm.

Tack the roll at 500mm intervals to the hip batten using staples or felt nails.

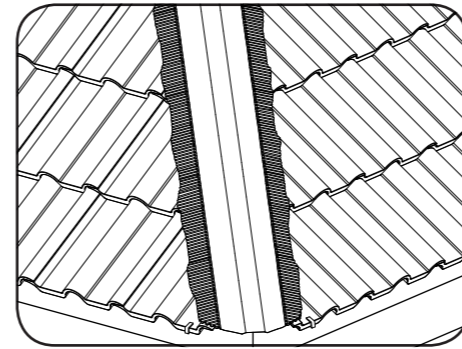

**6.** Remove the protective tape from the adhesive strip on the underside of the corrugated edge.

Push the entire length of the adhesive strip on to the tiles so that the corrugated strip moulds into the profile of the tiles.

Ensure that the Vent Roll is fully sealed along the entire hip on both sides. A roller can aid in this process.

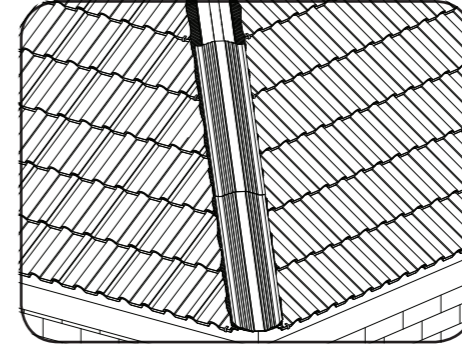

**7.** Trim a piece of hip support tray at the eaves to suit the overhang of the bottom course of tiles and secure in place using suitable nails. Continue up the hip with the remaining trays, overlapping the trays by 100mm at each join.

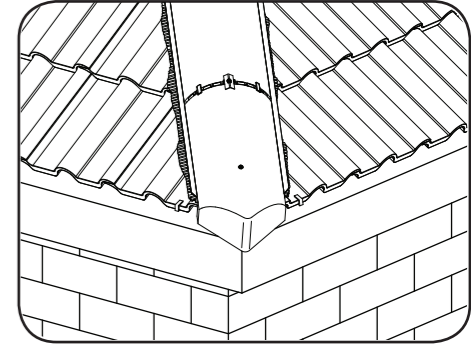

**8.** Using one of the 4" screws and washers provided, secure a block end hip tile in place ensuring the screw has adequate penetration into the hip batten.

Alternatively, a standard hip tile can be used in conjunction with the Manthorpe Hip End Closer (GDRH-HC).

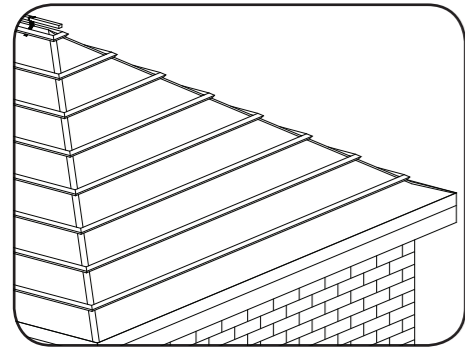

**9.** Continue tiling up the length of the hip placing a ridge union between each of the hip tiles. Securely fasten each ridge union in place by tightening the screw down into the hip rafter and that the metal clamp adequately clasps the hip tiles.

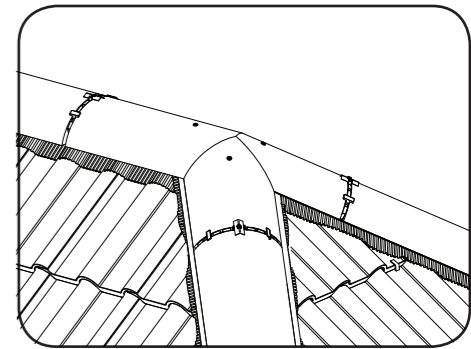

**10.** At the hip-ridge junction, ensure that the last tile in the run is a full length tile by cutting the previous tile down in length, if required. Mitre cut the three tiles at the junction to fit neatly together, drill and secure them in place with the screws provided. A small bed of mortar can be placed on the vent roll to support the mitred tiles. The mitred joints should be sealed with a suitable roofing grade waterproof sealant or lead saddle.