

Rigid Frame Former General Fitting

CODE **G280/G282**

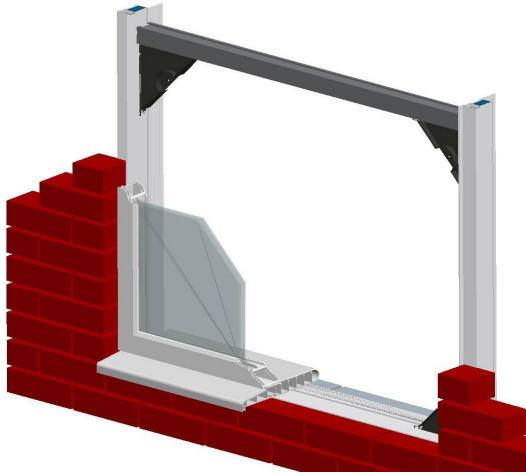

Locate frame into position ensuring flange sits flush with brick face.

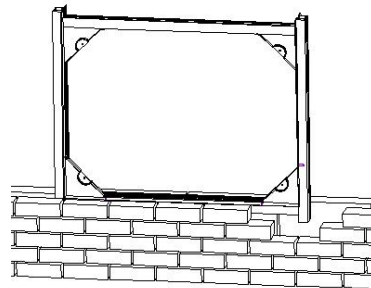

(1)

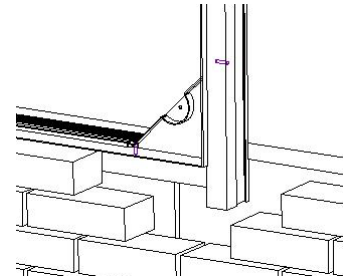

Installation:

- 1) Brick up the cavity wall to sill height in the conventional manner and place the preformed Rigid Frame Former in the correct position.

Note: In normal situations the large width flange sits on the inner leaf.

- 2) Continue to brick up wall construction using a fixing tie every third course or every 225mm in alternate internal and external construction.
- 3) On completion of brickwork unscrew and remove all corner strengtheners. Remove top brace by rotating through 90° and knocking one end down.
- 4) The former is now ready to accept the window / door frame which should be fixed in the conventional manner, allowing at least 30mm overlap from the back face of the frame into the cavity.

Installation is completed with the application of a weatherproof sealant between the frame and outer leaf and dry lining or plaster at the internal reveal.

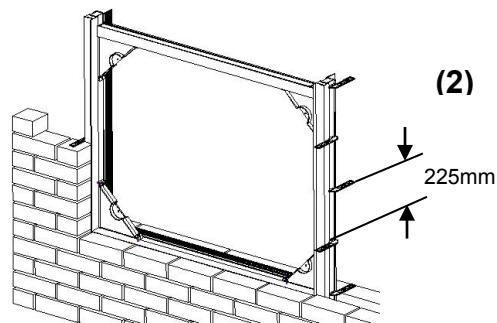

(2)

Frame Ties fixed alternate every third course (225mm).

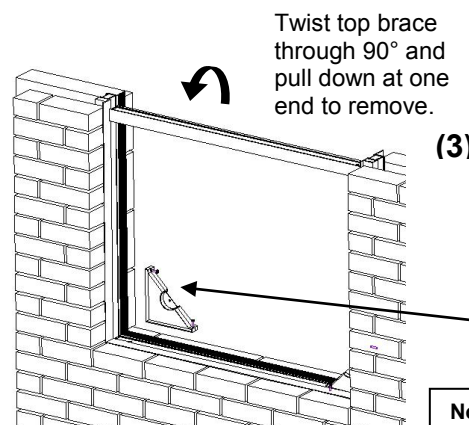

Twist top brace through 90° and pull down at one end to remove.

(3)

Note: - On larger windows, corner brackets will also be used at the top. These will also have to be removed before removing the brace.

Unscrew and remove all corner brackets.

Note: - Corner brackets and brace may be reused.

MANTHORPE BUILDING PRODUCTS LTD
MANTHORPE HOUSE
BRITAIN DRIVE
CODNOR GATE BUSINESS PARK
RIPLEY
DERBYSHIRE DE5 3ND

TEL: 01773 303 000
FAX: 01773 303 300
EMAIL:
mbp_care@manthorpebp.co.uk
WEB:
www.manthorpebp.co.uk

DRN M.A

Date 25.06.19

The company maintains a policy of continuous development of its product range and reserves the right to amend the specification without notice.

DRG No

MBP 8220

Issue

C