

Horizontal Tray

CODE **GW295**

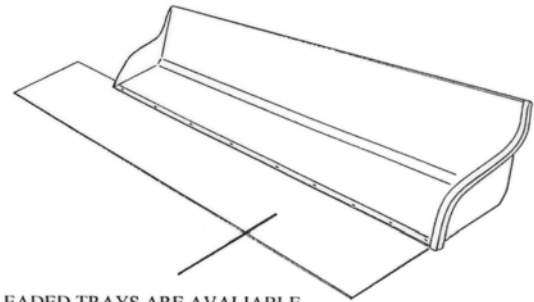
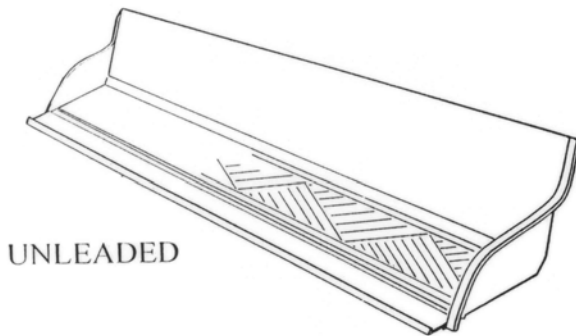

LEADED TRAYS ARE AVAILABLE
IN EITHER :-

	CODE 4	CODE 5
SHORT LEAD	75mm DROP	
STANDARD LEAD	150mm DROP	150 mm DROP
LONG LEAD	300mm DROP	350mm DROP

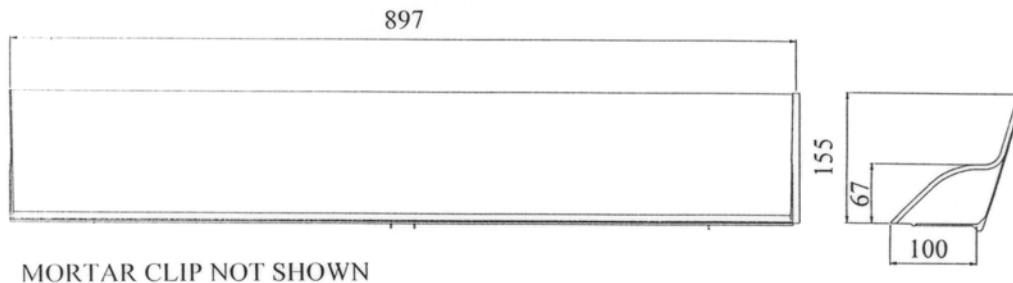

Description:

The GW295 Horizontal Tray is designed for straight horizontal abutments in new build situations. Integral stop ends and a hook feature removes the need for overlap of trays giving a total tray effective length of 900mm.

The tray has unique front mortar clips that can be easily removed once the mortar has set leaving a 25mm deep aperture into which the lead is inserted and secure with lead wedges.

Two G950 Weep Vents or G953 Diamond Weeps must be used in conjunction with this tray spaced at 450mm centres to meet current NHBC standards to drain away the collected water.

The GW295 Horizontal Tray can also be supplied with short, standard or long lead stapled and sealed to the tray in either code 4 or code 5 (special order).

COLOURS	Black
PACKING DETAILS	Packed in 25's in cardboard box (unleaded).
WEIGHT	12kg per box (unleaded)
MATERIAL	Polypropylene
MANUFACTURING PROCESS	Injection Moulded
SUITABLE FOR CAVITY WIDTHS	50mm to 100mm
SUITABLE FOR PITCHES	17.5 to 50
BED SIZE	102.5mm

References:

BRE	:	Building Elements Walls, Windows, Doors
BRE	:	DIGEST 262/380
BSI	:	BS5628
BSI	:	BS8000 Part 3
BSI	:	BS8215
NHBC	:	Standards 6.1

MANTHORPE BUILDING PRODUCTS LTD
MANTHORPE HOUSE
BRITAIN DRIVE
CODNOR GATE BUSINESS PARK
RIPLEY
DERBYSHIRE DE5 3ND

TEL: 01773 303 000
FAX: 01773 303 300
EMAIL:
mbp.care@manthorpebp.co.uk
WEB:
www.manthorpebp.co.uk

DRN M.L.W.O Date 21.06.19

The company maintains a policy of continuous development of its product range and reserves the right to amend the specification without notice.

DRG No

MBP 8038

Issue

C