

Refurbishment Tray

CODE **GW294**

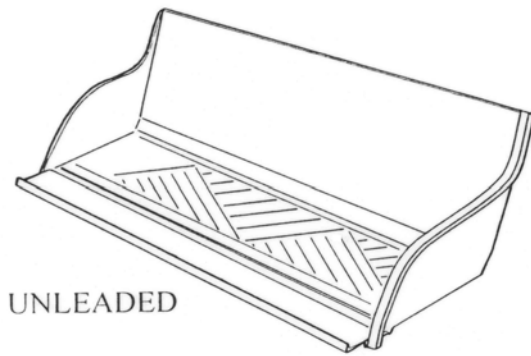

UNLEADED

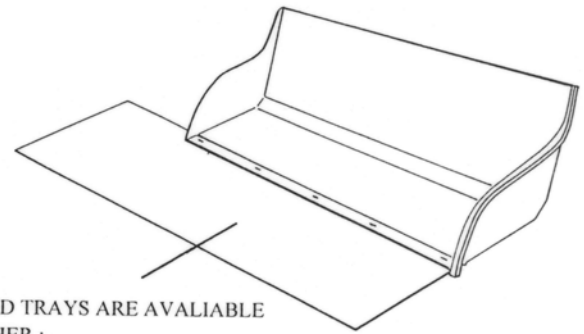

LEADED TRAYS ARE AVAILABLE IN EITHER :-

	CODE 4	CODE 5
SHORT LEAD	75mm DROP	
STANDARD LEAD	150mm DROP	150 mm DROP
LONG LEAD	300mm DROP	350mm DROP

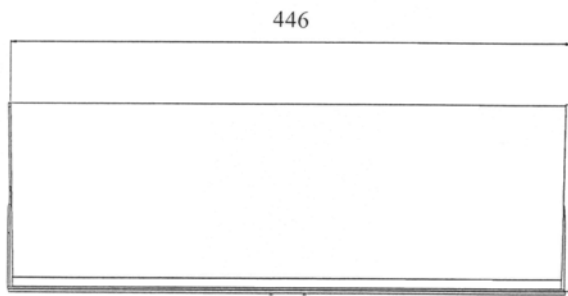

MORTAR CLIP NOT SHOWN

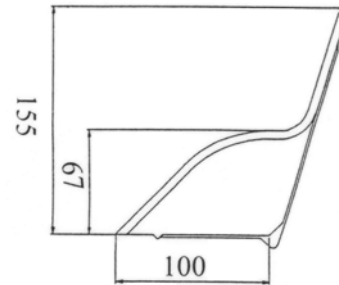

Description:

The GW294 Refurbishment Horizontal Tray is designed to provide protection where a new horizontal roof abutment meets an existing wall. It can also be used where the original system has been found to have degraded or even left out of the wall construction.

Alternatively it can be used in new build horizontal situations or in conjunction with the GW295 Horizontal Tray. Integral stop ends and a hook feature remove the need to overlap the trays giving a total effective length of 450mm.

The tray has a unique front mortar clip that can be removed at any time once the mortar has set leaving a 25mm deep aperture into which the lead is inserted and secured with lead wedges.

A G950 Weep Vent or G953 Diamond Weep must be used in each tray to drain away the collected water.

The GW294 Refurbishment Tray can also be supplied with short, standard or long lead stapled and sealed to the tray in either code 4 or code 5 (special order).

COLOURS	Black
PACKING DETAILS	Packed in 25's in cardboard box (unleaded).
WEIGHT	4.9kg per box (unleaded)
MATERIAL	Polypropylene
MANUFACTURING PROCESS	Injection Moulded
SUITABLE FOR CAVITY WIDTHS	50mm to 100mm
BED SIZE	102.5mm

References:

BRE	:	Building Elements Walls, Windows, Doors
BRE	:	DIGEST 262/380
BSI	:	BS5628
BSI	:	BS8000 Part 3
BSI	:	BS8215
NHBC	:	Standards 6.1

MANTHORPE BUILDING PRODUCTS LTD
MANTHORPE HOUSE
BRITAIN DRIVE
CODNOR GATE BUSINESS PARK
RIPLEY
DERBYSHIRE DE5 3ND

TEL: 01773 303 000
FAX: 01773 303 300
EMAIL: mbp.care@manthorpebp.co.uk
WEB: www.manthorpebp.co.uk

DRN M.L.W.O Date 21.06.19

The company maintains a policy of continuous development of its product range and reserves the right to amend the specification without notice.

DRG No

MBP 8037

Issue

C